

## 8W-01 WIRING DIAGRAM INFORMATION

### TABLE OF CONTENTS

	page		page
<b>WIRING DIAGRAM INFORMATION</b>			
DESCRIPTION		STANDARD PROCEDURE - TESTING FOR A SHORT TO GROUND.....	10
DESCRIPTION - HOW TO USE WIRING DIAGRAMS .....	1	STANDARD PROCEDURE - TESTING FOR A SHORT TO GROUND ON FUSES POWERING SEVERAL LOADS .....	10
DESCRIPTION - CIRCUIT INFORMATION .....	5	STANDARD PROCEDURE - TESTING FOR A VOLTAGE DROP .....	11
DESCRIPTION - CIRCUIT FUNCTIONS .....	5	SPECIAL TOOLS	
DESCRIPTION - SECTION IDENTIFICATION AND INFORMATION .....	6	WIRING/TERMINAL .....	12
DESCRIPTION - CONNECTOR, GROUND AND SPLICE INFORMATION .....	7	<b>CONNECTOR</b>	
WARNING		REMOVAL .....	13
WARNINGS - GENERAL .....	7	INSTALLATION .....	16
DIAGNOSIS AND TESTING - WIRING HARNESS .....	8	<b>DIODE</b>	
STANDARD PROCEDURE		REMOVAL .....	16
STANDARD PROCEDURE - ELECTROSTATIC DISCHARGE (ESD) SENSITIVE DEVICES .....	9	INSTALLATION .....	16
STANDARD PROCEDURE - TESTING OF VOLTAGE POTENTIAL.....	9	<b>TERMINAL</b>	
STANDARD PROCEDURE - TESTING FOR CONTINUITY .....	10	REMOVAL .....	16
		INSTALLATION .....	16
		<b>WIRE</b>	
		STANDARD PROCEDURE - WIRE SPLICING ..	17

## WIRING DIAGRAM INFORMATION

### DESCRIPTION

#### DESCRIPTION - HOW TO USE WIRING DIAGRAMS

DaimlerChrysler Corporation wiring diagrams are designed to provide information regarding the vehicles wiring content. In order to effectively use the wiring diagrams to diagnose and repair DaimlerChrysler Corporation vehicles, it is important to understand all of their features and characteristics.

Diagrams are arranged such that the power (B+) side of the circuit is placed near the top of the page, and the ground (B-) side of the circuit is placed near the bottom of the page.

All switches, components, and modules are shown in the at rest position with the doors closed and the key removed from the ignition.

Components are shown two ways. A solid line around a component indicates that the component is complete. A dashed line around the component indicates that the component is being shown is not complete. Incomplete components have a reference number to indicate the page where the component is shown complete.

It is important to realize that no attempt is made on the diagrams to represent components and wiring as they appear on the vehicle. For example, a short piece of wire is treated the same as a long one. In addition, switches and other components are shown as simply as possible, with regard to function only.

### SYMBOLS

International symbols are used throughout the wiring diagrams. These symbols are consistent with those being used around the world.

DIAGRAMS ARE ARRANGED WITH THE POWER B+ SIDE OF THE CIRCUIT NEAR THE TOP OF THE PAGE, AND THE GROUND SIDE OF THE CIRCUIT NEAR THE BOTTOM OF THE PAGE.

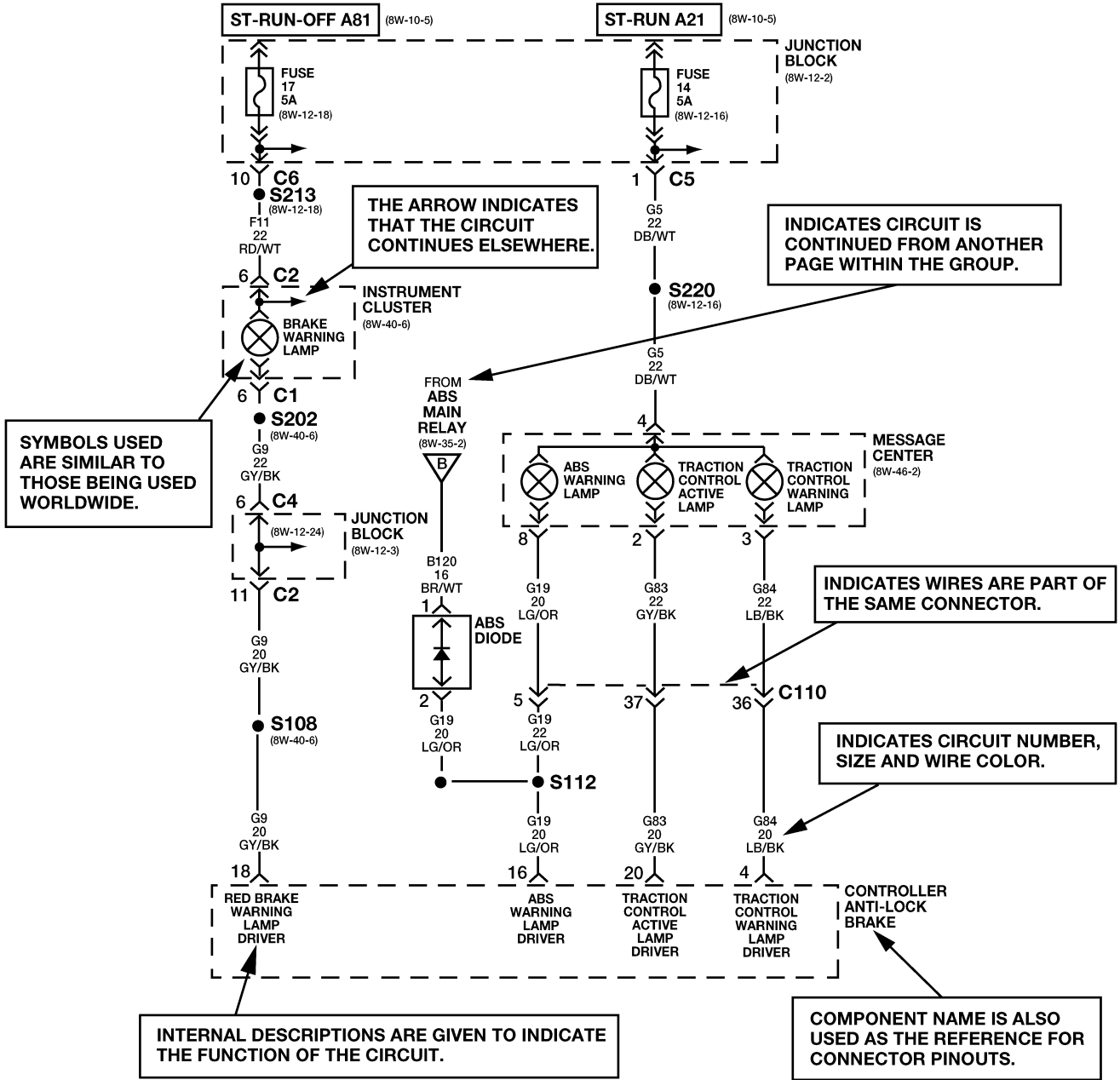

THE ARROW INDICATES THAT THE CIRCUIT CONTINUES ELSEWHERE.

INDICATES CIRCUIT IS CONTINUED FROM ANOTHER PAGE WITHIN THE GROUP.

SYMBOLS USED ARE SIMILAR TO THOSE BEING USED WORLDWIDE.

INDICATES WIRES ARE PART OF THE SAME CONNECTOR.

INDICATES CIRCUIT NUMBER, SIZE AND WIRE COLOR.







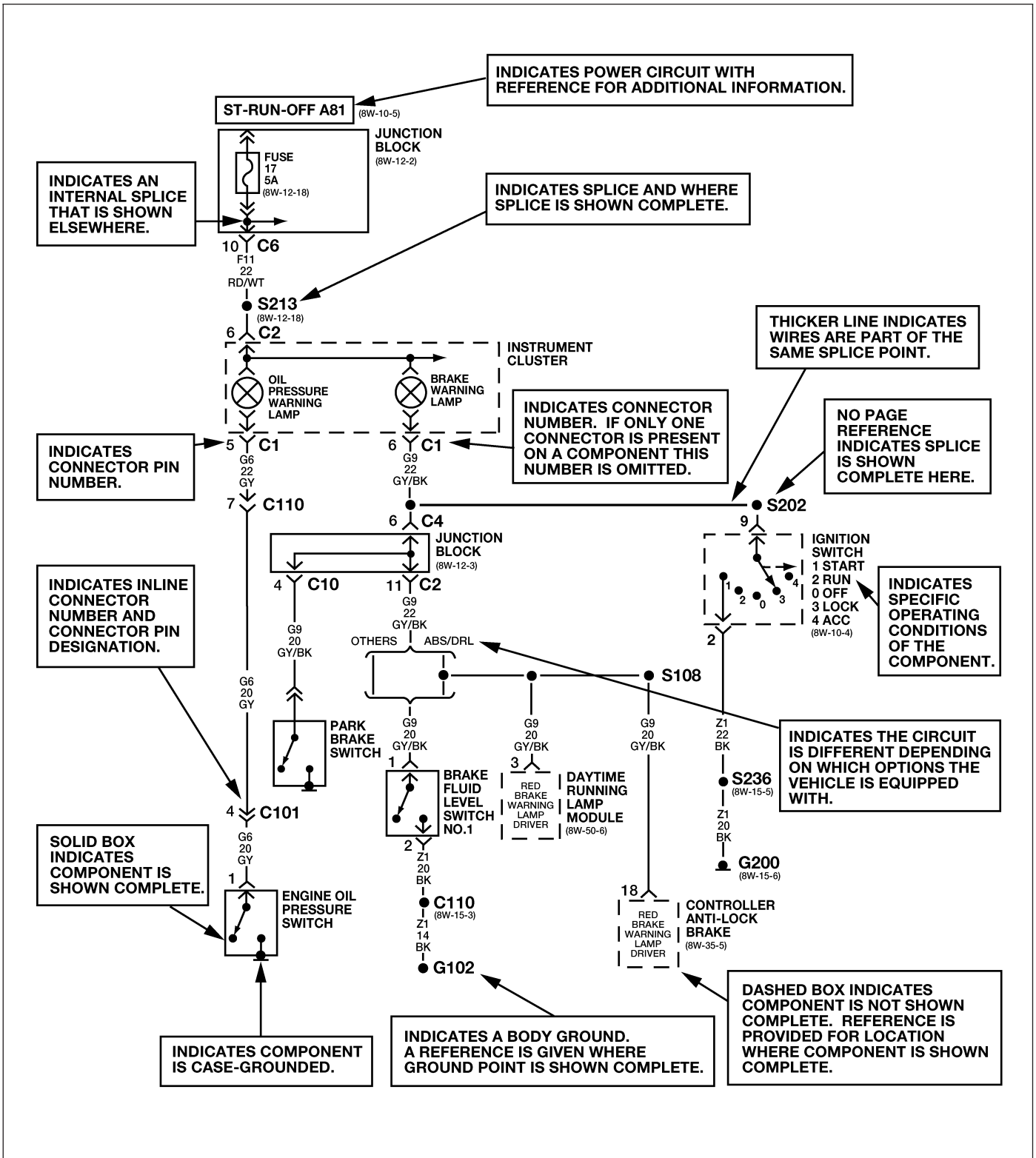



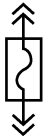
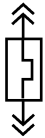

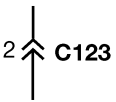
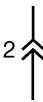



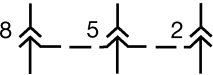











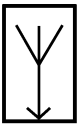
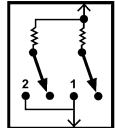
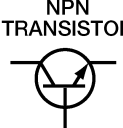
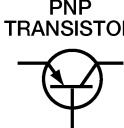
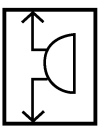
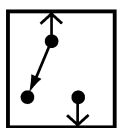
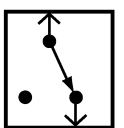
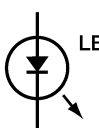
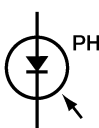

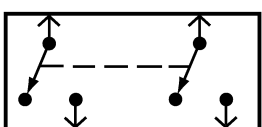
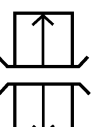

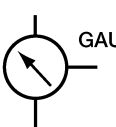

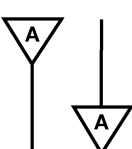

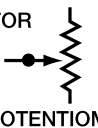
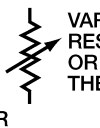
INTERNAL DESCRIPTIONS ARE GIVEN TO INDICATE THE FUNCTION OF THE CIRCUIT.

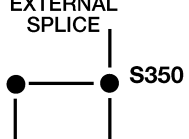
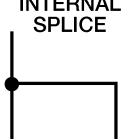
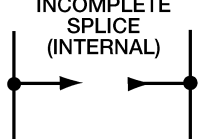
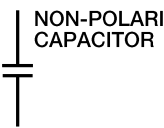
COMPONENT NAME IS ALSO USED AS THE REFERENCE FOR CONNECTOR PINOUTS.

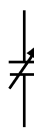
The System shown here is an **EXAMPLE ONLY**. It does not represent the actual circuit shown in the **WIRING DIAGRAM SECTION**.

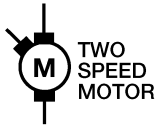
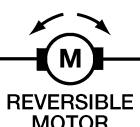

The System shown here is an EXAMPLE ONLY. It does not represent the actual circuit shown in the WIRING DIAGRAM SECTION.

 FUSIBLE LINK  FUSE  CIRCUIT BREAKER OR PTC PROTECTION DEVICE	 BATTERY  IN-LINE CONNECTORS 2  C123    2  C123
 BATT A0 HOT BAR  CHOICE BRACKET (8W-30-10) PAGE REFERENCE	 MULTIPLE CONNECTOR 8  C123    5  C123    2  C123  MALE CONNECTOR 4  C1  FEMALE CONNECTOR 6  C3
 CLOCKSPRING  GROUND G101  SCREW TERMINAL	 SINGLE FILAMENT LAMP  DUAL FILAMENT LAMP  ANTENNA
 RESISTIVE MULTIPLEX SWITCH	 NPN TRANSISTOR  PNP TRANSISTOR  TONE GENERATOR
 OPEN SWITCH  CLOSED SWITCH	 LED  PHOTODIODE  DIODE  ZENER DIODE
 GANGED SWITCH  SLIDING DOOR CONTACT	 OXYGEN SENSOR  GAUGE  PIEZOELECTRIC CELL
 WIRE ORIGIN & DESTINATION SHOWN WITHIN CELL  WIRE DESTINATION SHOWN IN ANOTHER CELL	 RESISTOR  POTENTIOMETER  VARIABLE RESISTOR OR THERMISTOR  HEATER ELEMENT
 EXTERNAL SPLICE S350  INTERNAL SPLICE  INCOMPLETE SPLICE (INTERNAL)	 NON-POLARIZED CAPACITOR  POLARIZED CAPACITOR  VARIABLE CAPACITOR
 ONE SPEED MOTOR  TWO SPEED MOTOR  REVERSIBLE MOTOR	 COIL  SOLENOID  SOLENOID VALVE

## TERMINOLOGY

This is a list of terms and definitions used in the wiring diagrams.

LHD	Left Hand Drive Vehicles
RHD	Right Hand Drive Vehicles
ATX	Automatic Transmissions-Front Wheel Drive
MTX	Manual Transmissions-Front Wheel Drive
AT	Automatic Transmissions-Rear Wheel Drive
MT	Manual Transmissions-Rear Wheel Drive
SOHC	Single Over Head Cam Engine
DOHC	Double Over Head Cam Engine
Export	Vehicles Built For Sale In Markets Other Than North America
Except Export	Vehicles Built For Sale In North America

## DESCRIPTION - CIRCUIT INFORMATION

Each wire shown in the diagrams contains a code which identifies the main circuit, a specific part of the main circuit, gage of wire, and color. An example would be **A 2 18 LB/YL**. This is a Battery Feed circuit, level two, eighteen gauge, light blue with a yellow tracer.

### WIRE COLOR CODE CHART

COLOR CODE	COLOR
BL	BLUE
BK	BLACK
BR	BROWN
DB	DARK BLUE
DG	DARK GREEN
GY	GRAY
LB	LIGHT BLUE
LG	LIGHT GREEN
OR	ORANGE
PK	PINK
RD	RED
TN	TAN
VT	VIOLET
WT	WHITE
YL	YELLOW
*	WITH TRACER

## DESCRIPTION - CIRCUIT FUNCTIONS

All circuits in the diagrams use an alpha/numeric code to identify the wire and it's function. To identify which circuit code applies to a system, refer to the Circuit Identification Code Chart. This chart shows the main circuits only and does not show the secondary codes that may apply to some models.

**CIRCUIT IDENTIFICATION CODE CHART**

<b>CIRCUIT</b>	<b>FUNCTION</b>
A	BATTERY FEED
B	BRAKE CONTROLS
C	CLIMATE CONTROLS
D	DIAGNOSTIC CIRCUITS
E	DIMMING ILLUMINATION CIRCUITS
F	FUSED CIRCUITS
G	MONITORING CIRCUITS (GAUGES)
H	MULTIPLE
I	NOT USED
J	OPEN
K	POWERTRAIN CONTROL MODULE
L	EXTERIOR LIGHTING
M	INTERIOR LIGHTING
N	MULTIPLE
O	NOT USED
P	POWER OPTION (BATTERY FEED)
Q	POWER OPTIONS (IGNITION FEED)
R	PASSIVE RESTRAINT
S	SUSPENSION/STEERING
T	TRANSMISSION/TRANSAXLE/ TRANSFER CASE
U	OPEN
V	SPEED CONTROL, WIPER/ WASHER
W	WIPERS
X	AUDIO SYSTEMS
Y	TEMPORARY
Z	GROUND

**DESCRIPTION - SECTION IDENTIFICATION AND INFORMATION**

The wiring diagrams are grouped into individual sections. If a component is most likely found in a particular group, it will be shown complete (all wires, connectors, and pins) within that group. For example, the Auto Shutdown Relay is most likely to be found in Group 30, so it is shown there complete. It can, however, be shown partially in another group if it contains some associated wiring.

Splice diagrams in Section 8W-70 show the entire splice and provide references to other sections the splices serves. Section 8W-70 only contains splice diagrams that are not shown in their entirety somewhere else in the wiring diagrams.

Section 8W-80 shows each connector and the circuits involved with that connector. The connectors are identified using the name/number on the diagram pages.

## DESCRIPTION - CONNECTOR, GROUND AND SPLICE INFORMATION

**CAUTION:** Not all connectors are serviced. Some connectors are serviced only with a harness. A typical example might be the Supplemental Restraint System connectors. Always check parts availability before attempting a repair.

### IDENTIFICATION

In-line connectors are identified by a number, as follows:

- In-line connectors located in the engine compartment are C100 series numbers.
- In-line connectors located in the instrument panel area are C200 series numbers.
- In-line connectors located in the body are C300 series numbers.
- Jumper harness connectors are C400 series numbers.
- Grounds and ground connectors are identified with a "G" and follow the same series numbering as the in-line connectors.
- Splices are identified with an "S" and follow the same series numbering as the in-line connectors.
- Component connectors are identified by the component name instead of a number. Multiple connectors on a component use a C1, C2, etc. identifier.

### LOCATIONS

Section 8W-91 contains connector/ground/splice location illustrations. The illustrations contain the connector name (or number)/ground number/splice number and component identification. Connector/ground/splice location charts in section 8W-91 reference the figure numbers of the illustrations.

The abbreviation T/O is used in the component location section to indicate a point in which the wiring harness branches out to a component. The abbreviation N/S means Not Shown in the illustrations

### WARNING

#### WARNINGS - GENERAL

**WARNINGS** provide information to prevent personal injury and vehicle damage. Below is a list of general warnings that should be followed any time a vehicle is being serviced.

**WARNING:** Always wear safety glasses for eye protection.

**WARNING:** Use safety stands anytime a procedure requires being under a vehicle.

**WARNING:** Be sure that the ignition switch always is in the off position, unless the procedure requires it to be on.

**WARNING:** Set the parking brake when working on any vehicle. An automatic transmission should be in park. A manual transmission should be in neutral.

**WARNING:** Operate the engine only in a well-ventilated area.

**WARNING:** Keep away from moving parts when the engine is running, especially the fan and belts.

**WARNING:** To prevent serious burns, avoid contact with hot parts such as the radiator, exhaust manifold(s), tail pipe, catalytic converter and muffler.

**WARNING:** Do not allow flame or sparks near the battery. Gases are always present in and around the battery.

**WARNING:** Always remove rings, watches, loose hanging jewelry and avoid loose clothing.

## DIAGNOSIS AND TESTING - WIRING HARNESS

### TROUBLESHOOTING TOOLS

When diagnosing a problem in an electrical circuit there are several common tools necessary. These tools are listed and explained below.

- Jumper Wire - This is a test wire used to connect two points of a circuit. It can be used to bypass an open in a circuit.

**WARNING:** Never use a jumper wire across a load, such as a motor, connected between a battery feed and ground.

- Voltmeter - Used to check for voltage on a circuit. Always connect the black lead to a known good ground and the red lead to the positive side of the circuit.

**CAUTION:** Most of the electrical components used in today's vehicles are Solid State. When checking voltages in these circuits, use a meter with a 10 - megohm or greater impedance rating.

- Ohmmeter - Used to check the resistance between two points of a circuit. Low or no resistance in a circuit means good continuity.

**CAUTION:** Most of the electrical components used in today's vehicles are Solid State. When checking resistance in these circuits use a meter with a 10 - megohm or greater impedance rating. In addition, make sure the power is disconnected from the circuit. Circuits that are powered up by the vehicle's electrical system can cause damage to the equipment and provide false readings.

- Probing Tools - These tools are used for probing terminals in connectors. Select the proper size tool from Special Tool Package 6807, and insert the probing end (2) into the terminal being tested. Use the other end of the tool (1) to insert the meter probe.

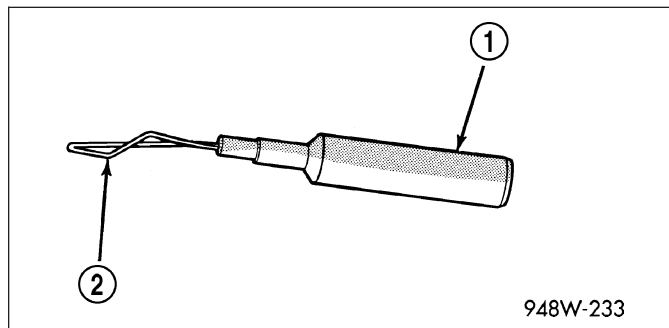

948W-233

### INTERMITTENT AND POOR CONNECTIONS

Most intermittent electrical problems are caused by faulty electrical connections or wiring. It is also possible for a sticking component or relay to cause a problem. Before condemning a component or wiring assembly, check the following items.

- Connectors are fully seated
- Spread terminals, or terminal push out
- Terminals in the wiring assembly are fully seated into the connector/component and locked into position
- Dirt or corrosion on the terminals. Any amount of corrosion or dirt could cause an intermittent problem
- Damaged connector/component casing exposing the item to dirt or moisture
- Wire insulation that has rubbed through causing a short to ground
- Some or all of the wiring strands broken inside of the insulation
- Wiring broken inside of the insulation

### TROUBLESHOOTING WIRING PROBLEMS

When troubleshooting wiring problems there are six steps which can aid in the procedure. The steps are listed and explained below. Always check for non-factory items added to the vehicle before doing any diagnosis. If the vehicle is equipped with these items, disconnect them to verify these add-on items are not the cause of the problem.



1. Verify the problem.
2. Verify any related symptoms. Do this by performing operational checks on components that are in the same circuit. Refer to the wiring diagrams.
3. Analyze the symptoms. Use the wiring diagrams to determine what the circuit is doing, where the problem most likely is occurring and where the diagnosis will continue.
4. Isolate the problem area.
5. Repair the problem area.
6. Verify the proper operation. For this step, check for proper operation of all items on the repaired circuit. Refer to the wiring diagrams.

## STANDARD PROCEDURE

### STANDARD PROCEDURE - ELECTROSTATIC DISCHARGE (ESD) SENSITIVE DEVICES

All ESD sensitive components are solid state and a symbol is used to indicate this. When handling any component with this symbol, comply with the following procedures to reduce the possibility of electrostatic charge build up on the body and inadvertent discharge into the component. If it is not known whether the part is ESD sensitive, assume that it is.

1. Always touch a known good ground before handling the part. This should be repeated while handling the part and more frequently after sliding across a seat, sitting down from a standing position, or walking a distance.
2. Avoid touching electrical terminals of the part, unless instructed to do so by a written procedure.
3. When using a voltmeter, be sure to connect the ground lead first.
4. Do not remove the part from its protective packing until it is time to install the part.
5. Before removing the part from its package, ground the package to a known good ground on the vehicle.

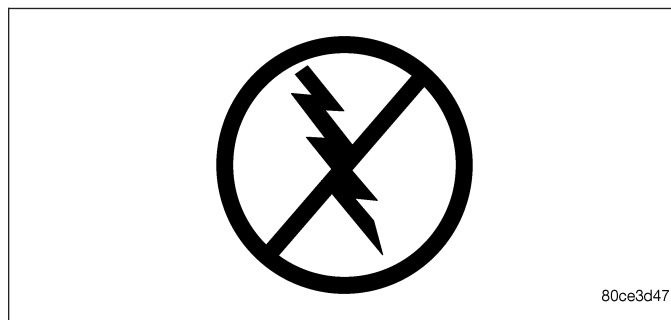

### STANDARD PROCEDURE - TESTING OF VOLTAGE POTENTIAL

1. Connect the ground lead of a voltmeter to a known good ground.
2. Connect the other lead of the voltmeter to the selected test point. The vehicle ignition may need to be turned ON to check voltage. Refer to the appropriate test procedure.

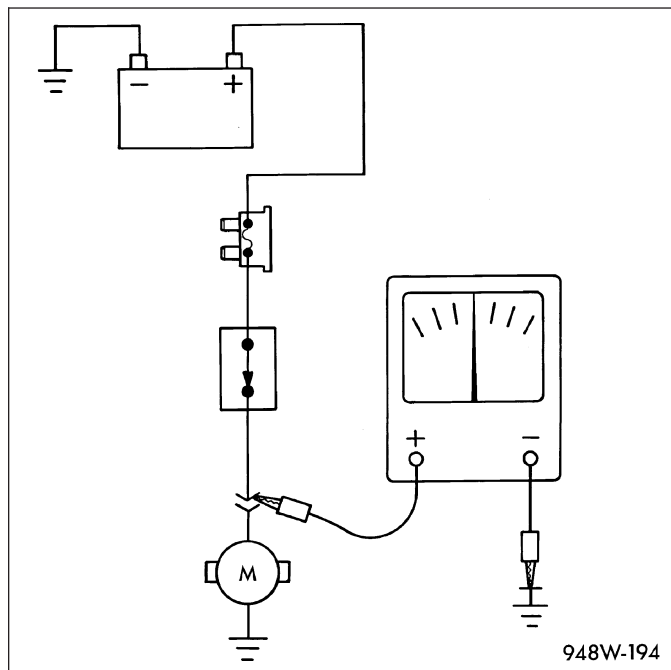

## STANDARD PROCEDURE - TESTING FOR CONTINUITY

1. Remove the fuse (1) for the circuit being checked or, disconnect the battery.
2. Connect one lead of the ohmmeter to one side of the circuit being tested
3. Connect the other lead to the other end of the circuit being tested. Low or no resistance means good continuity.

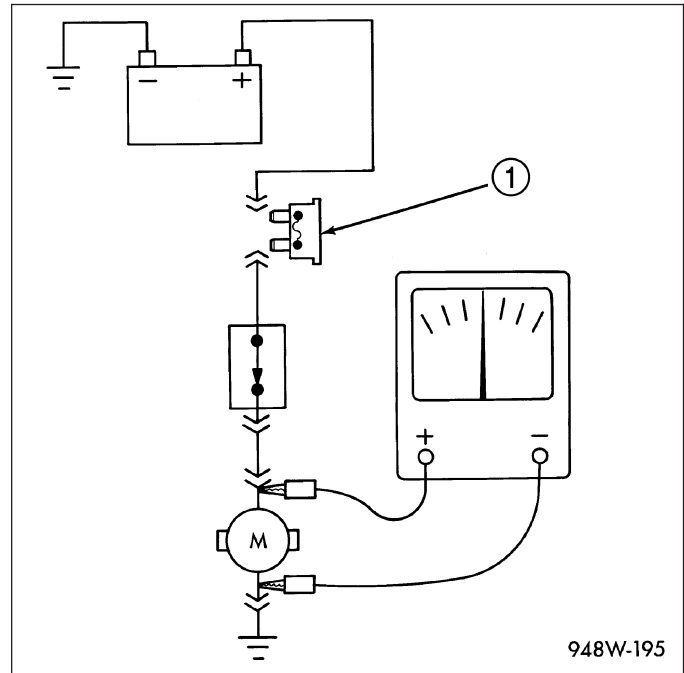

## STANDARD PROCEDURE - TESTING FOR A SHORT TO GROUND

1. Remove the fuse and disconnect all items involved with the fuse.
2. Connect a test light or a voltmeter across the terminals of the fuse.
3. Starting at the fuse block, wiggle the wiring harness about six to eight inches apart and watch the voltmeter/test lamp.
4. If the voltmeter registers voltage or the test lamp glows, there is a short to ground in that general area of the wiring harness.

## STANDARD PROCEDURE - TESTING FOR A SHORT TO GROUND ON FUSES POWERING SEVERAL LOADS

1. Refer to the wiring diagrams and disconnect or isolate all items on the suspected fused circuits.
2. Replace the blown fuse.
3. Supply power to the fuse by turning ON the ignition switch or re-connecting the battery.
4. Start connecting or energizing the items in the fuse circuit one at a time. When the fuse blows the circuit with the short to ground has been isolated.

**STANDARD PROCEDURE - TESTING FOR A VOLTAGE DROP**

1. Connect the positive lead of the voltmeter to the side of the circuit closest to the battery.
2. Connect the other lead of the voltmeter to the other side of the switch, component or circuit.
3. Operate the item.
4. The voltmeter will show the difference in voltage between the two points.

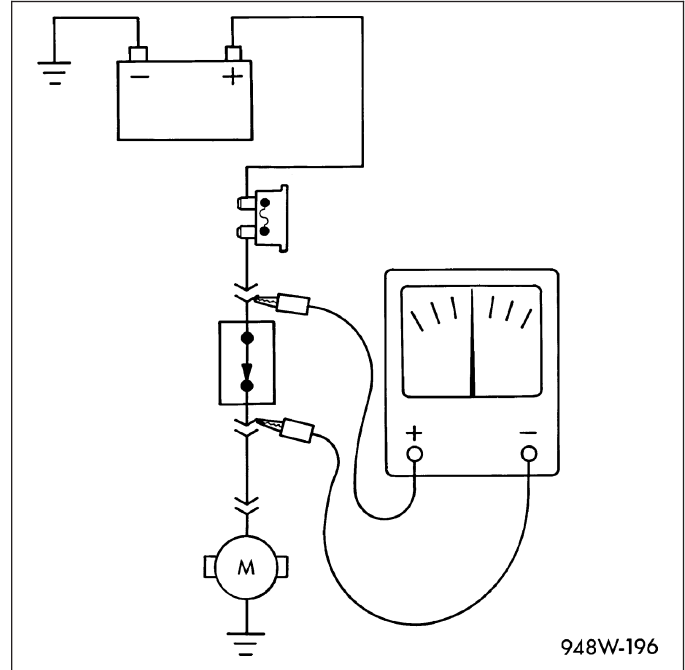

### SPECIAL TOOLS

### WIRING/TERMINAL

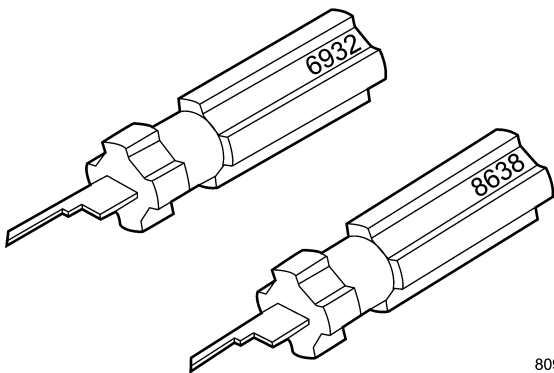
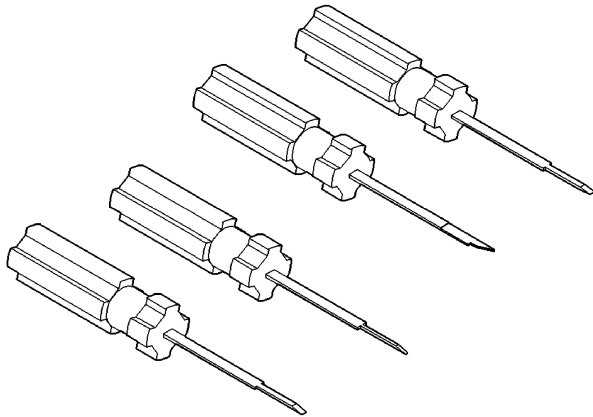
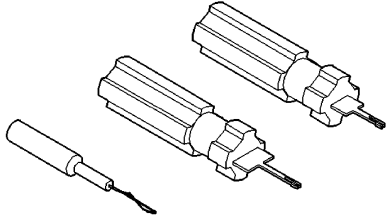

8091c8da

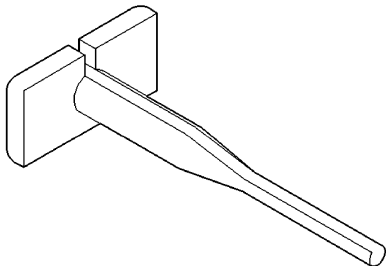

## CONNECTOR

### REMOVAL

1. Disconnect battery.
2. Release Connector Lock (2).
3. Disconnect the connector (3) being repaired from its mating half/component.
4. Remove the dress cover (if applicable) (1).

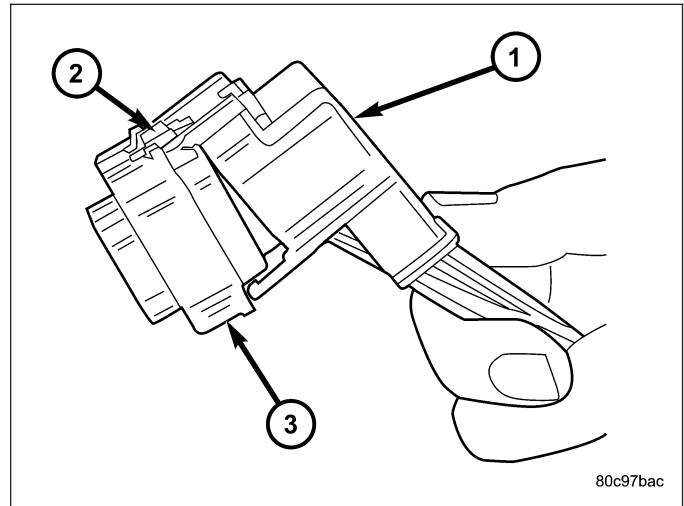

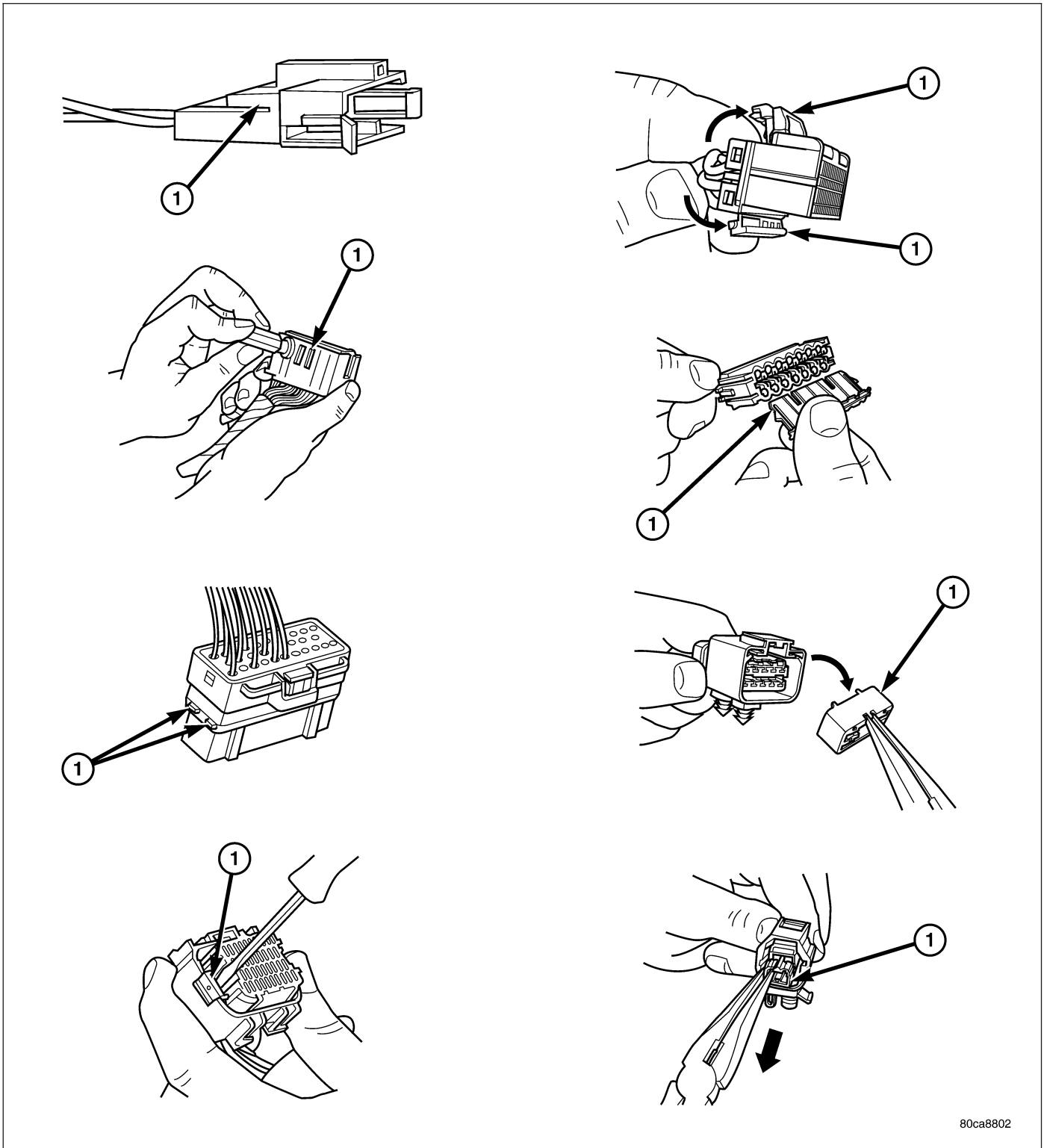

80ca8802

5. Release the Secondary Terminal Lock, if required (1).

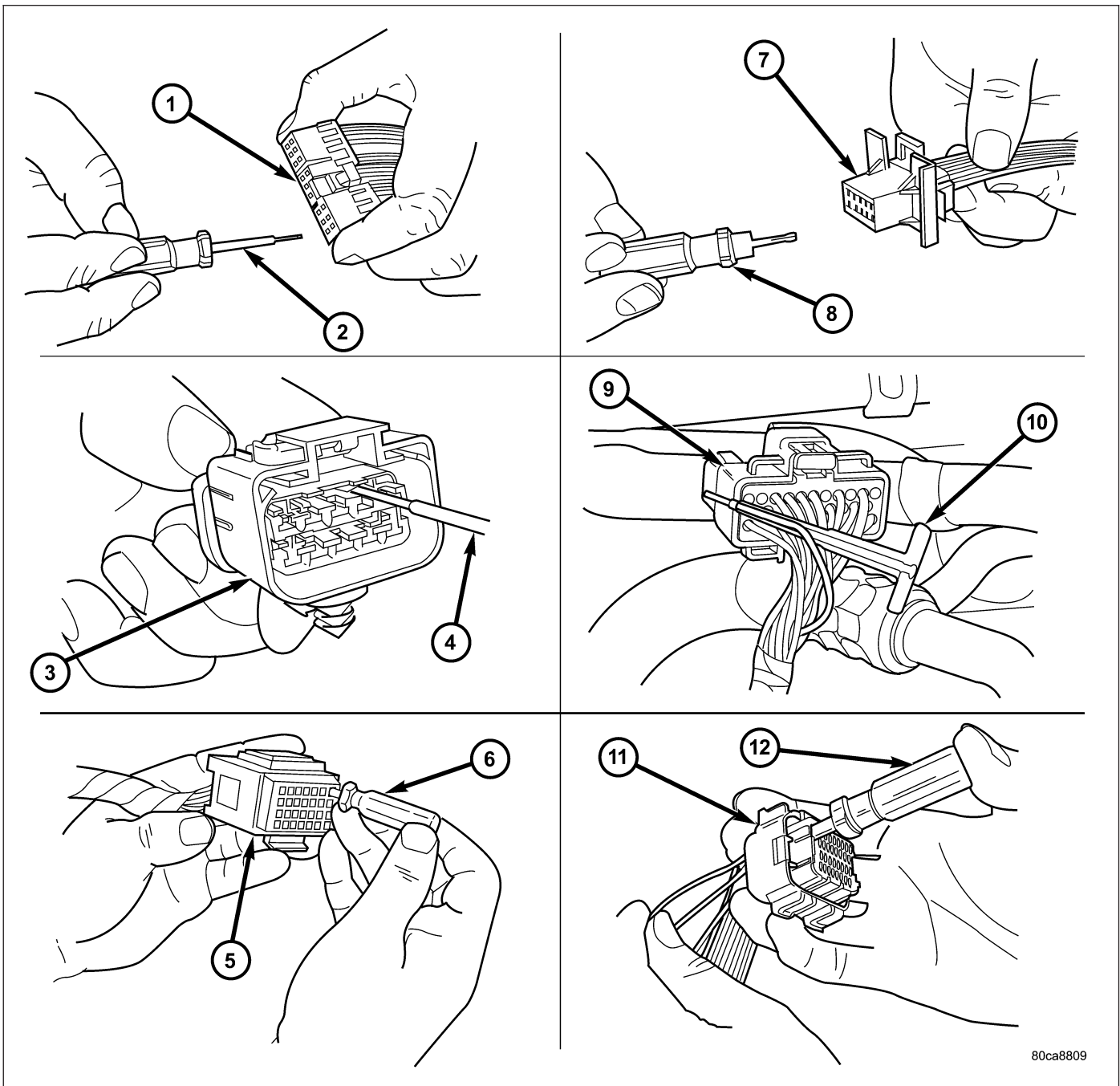

80ca8809

- 1 - TYPICAL CONNECTOR
- 2 - PICK FROM SPECIAL TOOL KIT 6680
- 3 - APEX CONNECTOR
- 4 - PICK FROM SPECIAL TOOL KIT 6680
- 5 - AUGAT CONNECTOR
- 6 - SPECIAL TOOL 6932

- 7 - MOLEX CONNECTOR
- 8 - SPECIAL TOOL 6742
- 9 - THOMAS AND BETTS CONNECTOR
- 10 - SPECIAL TOOL 6934
- 11 - TYCO CONNECTOR
- 12 - SPECIAL TOOL 8638

6. Position the connector locking finger away from the terminal using the proper special tool. Pull on the wire to remove the terminal from the connector.

## INSTALLATION

1. Insert the removed terminal in the same cavity on the repair connector.
2. Repeat steps for each terminal in the connector, being sure that all wires are inserted into the proper cavities. For additional connector pin-out identification, refer to the wiring diagrams.
3. When the connector is re-assembled, the secondary terminal lock must be placed in the locked position to prevent terminal push out.
4. Replace dress cover (if applicable).
5. Connect connector to its mating half/component.
6. Connect battery and test all affected systems.

## DIODE

### REMOVAL

1. Disconnect the battery.
2. Locate the diode in the harness, and remove the protective covering.
3. Remove the diode from the harness, pay attention to the current flow direction (1) (2) (3).

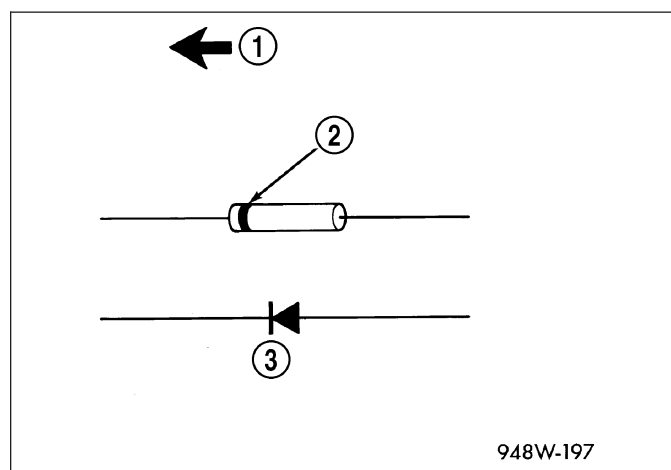

### INSTALLATION

1. Remove the insulation from the wires in the harness. Only remove enough insulation to solder in the new diode.
2. Install the new diode in the harness, making sure current flow is correct. If necessary, refer to the appropriate wiring diagram for current flow.
3. Solder the connection together using rosin core type solder only. **Do not use acid core solder.**
4. Tape the diode to the harness using electrical tape. Make sure the diode is completely sealed from the elements.
5. Re-connect the battery and test affected systems.

## TERMINAL

### REMOVAL

1. Follow steps for removing terminals described in the connector removal section.
2. Cut the wire 6 inches from the back of the connector.

### INSTALLATION

1. Select a wire from the terminal repair kit that best matches the color and gage of the wire being repaired.
2. Cut the repair wire to the proper length and remove one-half (1/2) inch of insulation.
3. Splice the repair wire to the wire harness (see wire splicing procedure) .
4. Insert the repaired wire into the connector.
5. Install the connector locking wedge, if required, and reconnect the connector to its mating half/component.
6. Re-tape the wire harness starting at 1-1/2 inches behind the connector and 2 inches past the repair.
7. Connect battery and test all affected systems.



## WIRE

### STANDARD PROCEDURE - WIRE SPLICING

When splicing a wire, it is important that the correct gage be used as shown in the wiring diagrams.

1. Remove one-half (1/2) inch of insulation from each wire that needs to be spliced.
2. Place a piece of adhesive lined heat shrink tubing on one side of the wire. Make sure the tubing will be long enough to cover and seal the entire repair area.
3. Place the strands of wire overlapping each other inside of the splice clip (1).

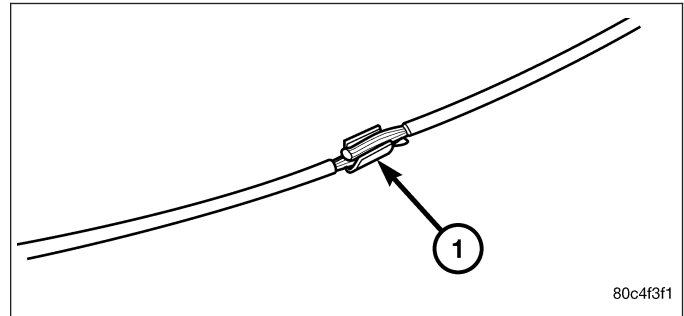

4. Using crimping tool (1), Mopar p/n 05019912AA, crimp the splice clip and wires together.

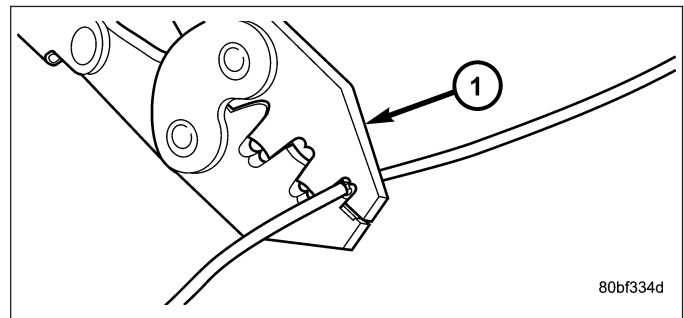

5. Solder (3) the connection (2) together using rosin core type solder (1) only.

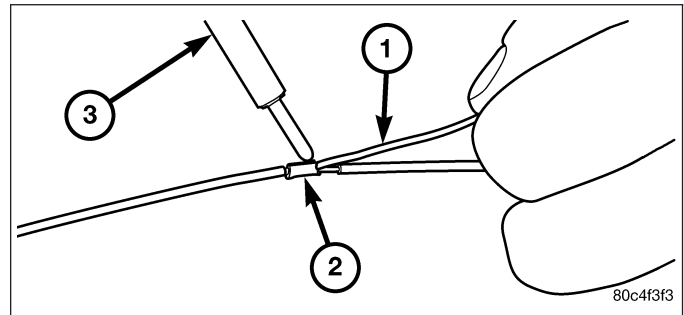

#### CAUTION: DO NOT USE ACID CORE SOLDER.

6. Center the heat shrink tubing (2) over the joint and heat using a heat gun. Heat the joint until the tubing is tightly sealed and sealant (1) comes out of both ends of the tubing.

