

8W-50 FRONT LIGHTING

Component	Page	Component	Page
Cluster	8W-50-2, 5	Lamp-Clearance No. 5	8W-50-6
Fuse 2	8W-50-2	Lamp-Fog-Left Front	8W-50-5
Fuse 14	8W-50-4	Lamp-Fog-Right Front	8W-50-5
Fuse 16	8W-50-4	Lamp-Headlamp-Left	8W-50-3
G104	8W-50-3, 4, 5	Lamp-Headlamp-Right	8W-50-3
G106	8W-50-3, 4	Lamp-Park-Left	8W-50-4
G201	8W-50-2	Lamp-Park-Right	8W-50-4
G203	8W-50-5, 6	Lamp-Park/Turn-Left Front	8W-50-4
Lamp-Center Bezel	8W-50-6	Lamp-Park/Turn-Right Front	8W-50-4
Lamp-Clearance No. 1	8W-50-6	Lamp-Tail Stop/Turn-Right	8W-50-4
Lamp-Clearance No. 2	8W-50-6	Module-Totally Integrated Power ..	8W-50-2, 3, 4, 5
Lamp-Clearance No. 3	8W-50-6	Switch-Headlamp	8W-50-2, 5
Lamp-Clearance No. 4	8W-50-6	Switch-Multifunction	8W-50-2

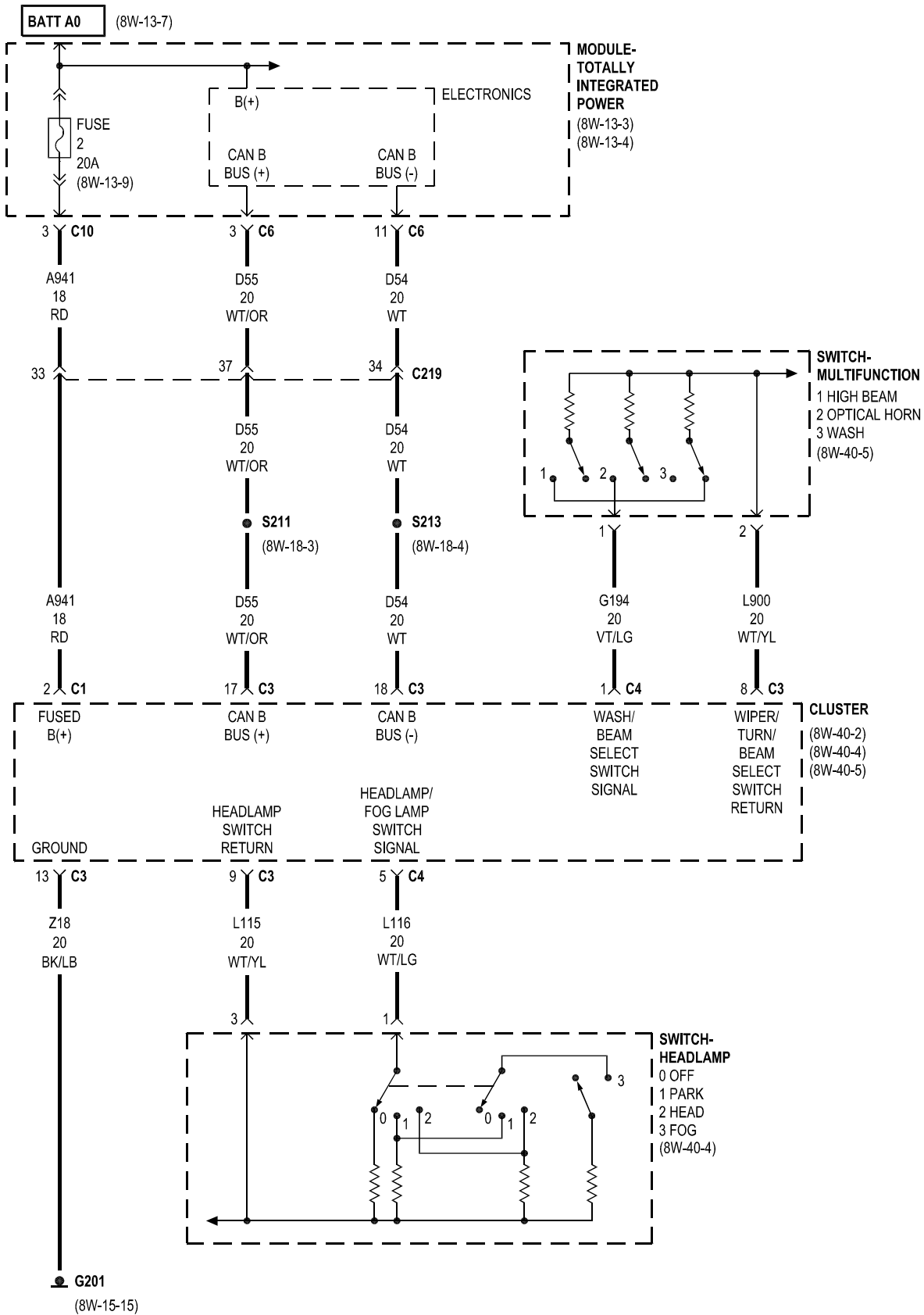

⊗ NOTE: D54, D55 CIRCUITS ARE TWISTED PAIR

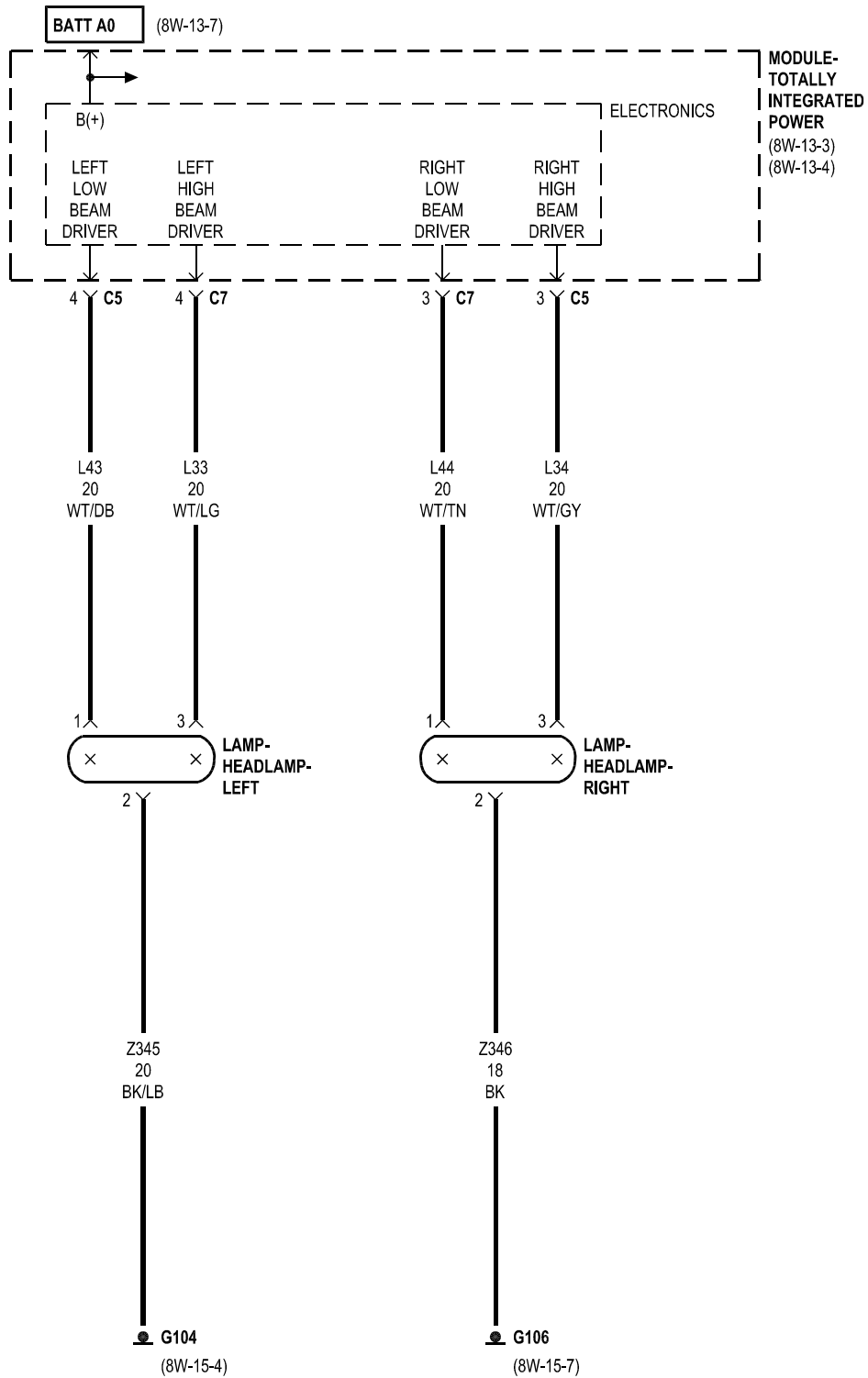

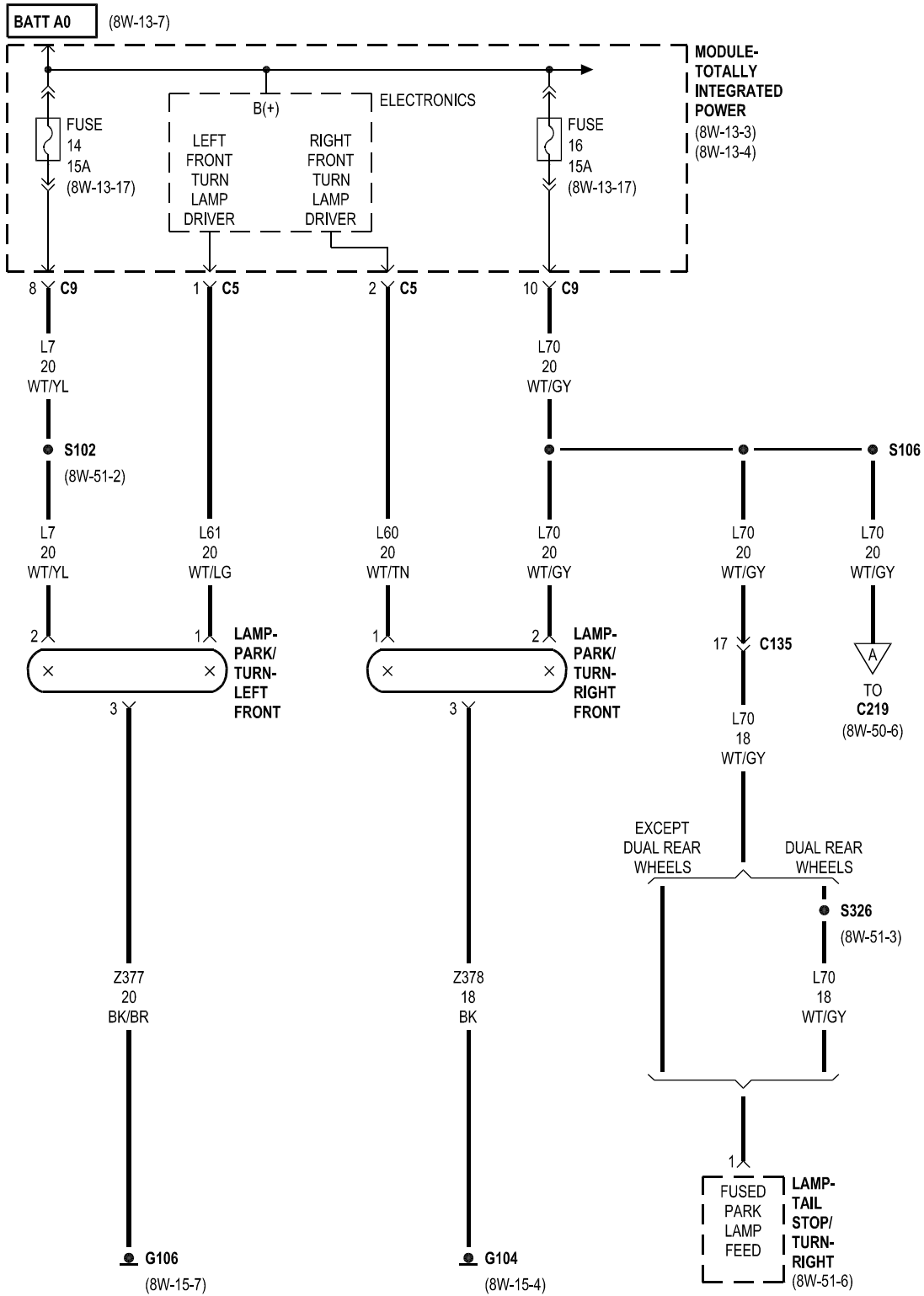

8W-50 FRONT LIGHTING EXCEPT BASE

