

# 2009 CHASSIS CAB EXTERIOR LIGHTING MODIFICATIONS

## Modifying the exterior lighting of the Ram truck starting with 2006 Model Year

The Ram truck has been designed and developed using standard incandescent lights. These lights are controlled by a computerized module called the “Totally Integrated Power Module” (TIPM). This module controls the left front, right front, left rear and right rear lighting independently. The TIPM utilizes “smart” technology that has the ability to monitor the current (amp) on some of the lighting outputs. These monitored outputs include the headlamps, turn lamps, stop lamps and reverse lamps. The module is able to detect both electrical short and open circuit conditions. The module has a preset allowable current (amp) operating range for each of these outputs. If while in normal operation the current detected falls outside this preset range, then a fault is set in the module. In the case of too high of current the circuit will be shut off. This fault condition will remain true until the current level falls back into the normal range. In the case of the turn lamp circuits, if the module detects too low of current then the module will assume an open circuit condition (burned out bulb) and the blinker will flash at a double flash rate.

This detection is in place to assist the customer in determining if there is an active short in the lighting circuit or a burned out bulb (open circuit).

You can also get into these fault conditions by adding additional lamps to the circuits or by changing the lamp specifications (i.e. changing the type of lamp used). This would include, but is not limited to, the use of L.E.D.'s. By using them you run the risk of causing lighting faults or loss of lighting functionality.

The question then becomes, “can you use L.E.D. lighting on the 2006 and beyond Ram trucks”? The answer is yes, but special care and procedures need to be followed to use L.E.D.s successfully.

### Use of L.E.D. lamps in conjunction with the original equipment incandescent lamps:

If you are keeping the original incandescent lamps (or the aftermarket equivalent) and you want to add additional L.E.D. lamps for use as stop, turn, reverse or park lamp function you can do so with no additional changes to the vehicle or its electrical system.

### Use of L.E.D. lamps without the original equipment incandescent lamps (2007-2009):

In order to use L.E.D. lamps in place of the original incandescent lamps you must use a resistor that matches the original lamps resistance. For the stop/turn function on the 2007/2009 Ram truck that would be a 6ohm resistor wired in **PARALLEL** with the L.E.D. lamps. A 6 ohm resistor matches our OEM bulbs. However it is recommended that a 1000 ohms 1 watt resistor be used so that the amperage draw is minimized. It should be capable of surviving exterior exposure on the vehicle with consideration for vibration and expected life cycle. As power resistors get hot under normal operation it is suggested that they be placed in an area with adequate ventilation and heat dissipation. It is further suggested that the resistor be located very near the L.E.D. lamp. This is to help with any future service related maintenance or repairs to the lighting circuits or lamps.

### 2010 and beyond

Alternatively for 2010 and forward, the Ram dealer has the ability to turn “off” bulb out detection for the rear stop & turn lamps. This is accomplished by having a Dealer add the sales code “LBQ” to the vehicle configuration file in the TIPM module. By doing so you will not need to add any resistors to the lighting circuits to prevent a fast flash or lamp out warning.

## 2009 CHASSIS CAB EXTERIOR LIGHTING MODIFICATIONS

### Adding additional incandescent lamps to the original equipment incandescent lamps:

Customers sometimes desire to add additional lamps to the exterior lighting circuits. This is possible but requires adding a relay to control the additional lamps. By correctly wiring the relay into the lighting circuit you only add the additional coil resistance of the relay. This will maintain the correct operating current (amp) range of the circuits and no faults will be set. A relay will need to be added to each side of the vehicle (left and right).

Below is a sample relay circuit which can be utilized to add additional lamps

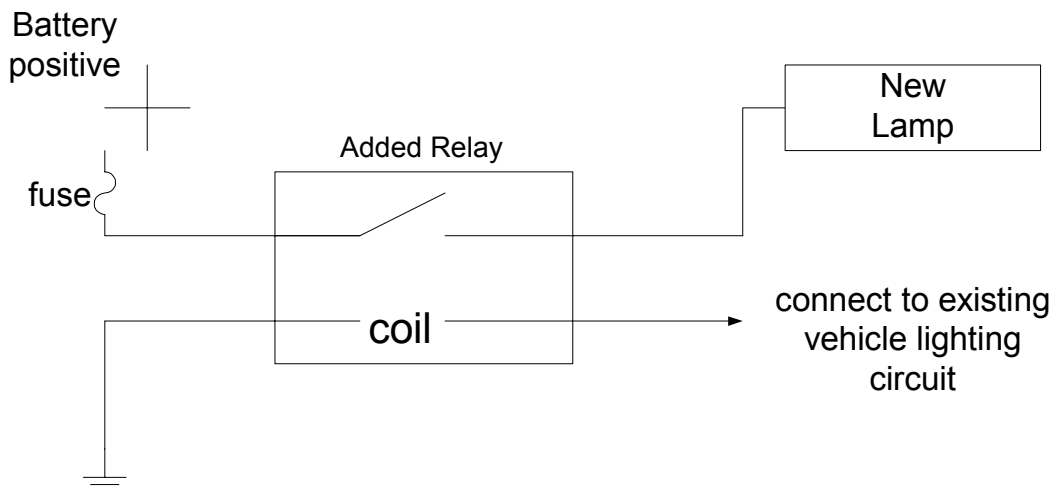

When this type of circuit is used please understand that there is no way for the vehicle to perform any diagnostics on the added lamps.

As a general statement the TIPM (Totally Integrated Power Module) does not provide a large enough current range on the head, turn, stop or reverse lamp circuits to add any additional incandescent lamp loads. It is therefore strongly recommended that the above procedures are followed for modifying the exterior lighting.

### Separated rear tail lighting

All of Ram Chassis Cab vehicles come from the factory with “combined rear lighting”, (stop/turn circuit use the same wire). For applications that require the stop and turn functions to be separated the following procedure can be used to accomplish this:

1. Use Dodge service tool (Dealer tool) to change rear lighting to separated or NOT combined.
2. Use the existing OEM tail lamp circuits. The existing stop/turn circuit becomes the separated turn circuit.
3. Pick up the stop lamp circuit (L50) from the trailer tow circuits at the rear of the vehicle. This becomes the separated stop lamp feed for both left and right side lamps.

Please remember it is necessary to use the OEM lamp circuits in order to prevent a lamp out warning and double flash rate of the turn circuits. The only trailer tow circuit to be used is the STOP LAMP feed.