

Modifying The Exterior Lighting

Note 1: Use the existing vehicle wires to the rear lamps, the trailer tow circuits are only for a trailer.

Note 2: Individual vehicle wiring circuits to left (drivers side) and right (passenger side) lighting **MUST** be kept separate, as designed. Do NOT power both left and right side bulbs/LED's from only either the left or right circuits, unless designed as such by Chrysler. Attempting to power both the left and right side lighting from one circuit may result in excess current draw on that circuit resulting in a fault code and possible circuit disable. Also leaving either a left or right side circuit without a lighting load will result in a fault code because the Central Body Computer will see the unused circuit as "burned-out" or disconnected lighting.

Note 3: When replacing incandescent bulbs with high efficiency LED's, these LED's may exhibit a faint glow even without the vehicle lighting being activated. This is normal and a result of the electronics in the Central Body Computer.

Replacing rear incandescent bulbs with LED's

Stop / Turn Lamps

For 2014 there are two different methods to eliminate fast flash and error codes when replacing rear stop/turn incandescent bulbs with LED's:

*Method (A) –

Ground circuit (Ground this circuit before disconnecting the OEM incandescent bulbs)

L950 LG/WT located in the driver side fender inner, location H. The circuit is accessed by removing the PDC in front of the battery and reaching into the fender inner. See "Upfitter Wiring Interface Instructions" of "Upfitter Electrical Instructions".

Alternate method (B) -

Add power resistors to the rear light circuits. This is the same procedure that could be employed from previous model years. Wire a 9 or 10 ohm, 50 watt power resistor in parallel with each LED's +12V feed wire and to ground. The resistors must be capable of surviving exterior exposure on the vehicle with consideration for vibration and expected life cycle. As power resistors may get hot under normal operation it is suggested that they be placed in an area with adequate ventilation and heat dissipation. It is further suggested that they be located very near the LED's; this is to help with any future service related maintenance or repairs to the lighting circuits.

*If the OEM incandescent bulbs are disconnected before circuits L950 from Method (A) is grounded and fast flash/faults are indicated - simply reconnect the OEM incandescent bulbs, unground the circuit, turn the vehicle switch to the run position, and:

1. actuate the left turn signal and wait for the fast flash to cease
2. actuate the right turn signal and wait for the fast flash to cease
3. press the brake pedal and wait for the fast flash to cease
4. re-ground the L950 circuit, and remove the OEM incandescent bulbs/re-connect the LED's.

Back-Up Lamps

For 2014 there is one method to eliminate fast flash and error codes when replacing back-up incandescent bulbs with LED's :



Add power resistors to the rear light circuits. This is the same procedure that could be employed from previous model years. Wire a 9 or 10 ohm, 50 watt power resistor in parallel with each LED's +12V feed wire and to ground. The resistors must be capable of surviving exterior exposure on the vehicle with consideration for vibration and expected life cycle. As power resistors may get hot under normal operation it is suggested that they be placed in an area with adequate ventilation and heat dissipation. It is further suggested that they be located very near the LED's; this is to help with any future service related maintenance or repairs to the lighting circuits.

General Info

The Ram truck has been designed and developed using standard incandescent lights. These lights are controlled by a computerized module called the "Central Body Controller" (CBC). This module controls the left front, right front, left rear and right rear lighting independently. The CBC utilizes "smart" technology that has the ability to monitor the current (amperage) on some of the lighting outputs. These monitored outputs include the headlamps, turn lamps, stop lamps and reverse lamps. The module is able to detect both electrical short and open circuit conditions. The module has a preset allowable current (amperage) operating range for each of these outputs. If while in normal operation the current detected falls outside this preset range, then a fault is set in the module. In the case of too high of current the circuit will be shut off. This fault condition will remain true until the current level falls back into the normal range. In the case of the turn lamp circuits, if the module detects too low of current then the module will assume an open circuit condition (burned out bulb) and the blinker will flash at a double flash rate.

This detection is in place to assist the customer in determining if there is an active short in the lighting circuit or a burned out bulb (open circuit).

You can also get into these fault conditions by adding additional lamps to the circuits or by changing the lamp specifications (i.e. changing the type of lamp used). This would include, but is not limited to, the use of LED's. By using them you run the risk of causing lighting faults or loss of lighting functionality.

The question then becomes, "can you use LED lighting on Ram trucks"? The answer is yes, but special care and procedures need to be followed to use LEDs successfully.

A)

Use of LED lamps in conjunction with the original equipment incandescent lamps:

If you are keeping the original incandescent lamps (or the aftermarket equivalent) and you want to add additional LED lamps for use as stop, turn, reverse or park lamp function you can do so with no additional changes to the vehicle or its electrical system.

B)

Adding additional incandescent lamps to the original equipment incandescent lamps:

Customers sometimes desire to add additional lamps to the exterior lighting circuits. This is possible but requires adding a relay to control the additional lamps. By correctly wiring the relay into the lighting circuit you only add the additional coil resistance of the relay. This will maintain the correct operating current (amp) range of the circuits and no faults will be set. A relay will need to be added to each side of the vehicle (left and right). Below is a sample relay circuit which can be utilized to add additional lamps

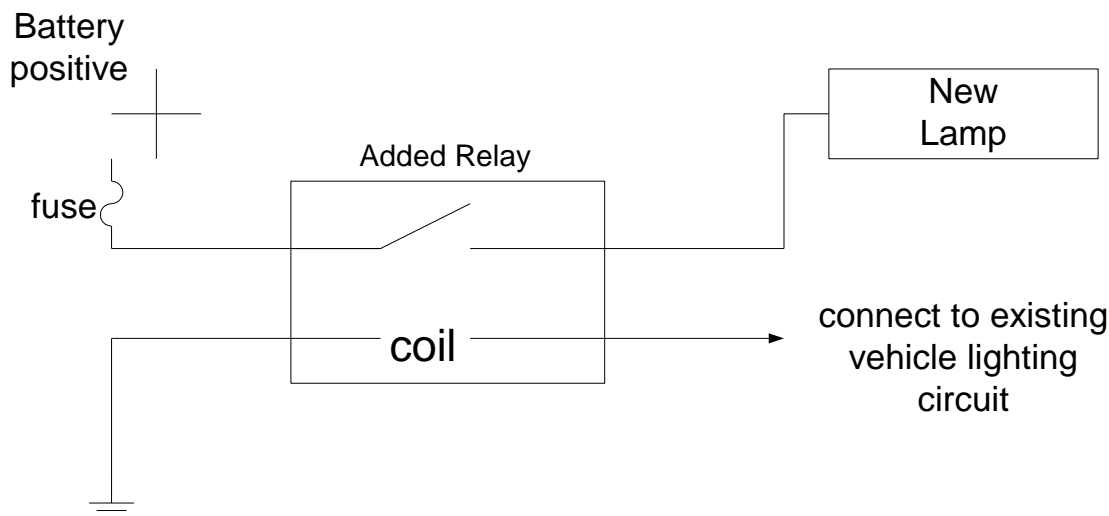

When this type of circuit is used please understand that there is no way for the vehicle to perform any diagnostics on the added lamps.

As a general statement the CBC does not provide a large enough current range on the head, turn, stop or reverse lamp circuits to add any additional incandescent lamp loads. It is therefore strongly recommended that the above procedures are followed for modifying the exterior lighting.