

CHASSIS CAB 4500/5500  
197.4"WB 84"CA FUEL TANK

NOTE:

**AUXILLARY FUEL PORT**

An auxillary fuel tap is provided on gas and diesel fuel tanks to provide fuel for secondary power systems. This is located on top of the fuel pump module and is sealed with a connector. This system will not drain the vehicle fuel completely. There will be sufficient fuel to drive back from the worksite.

Utilize due care when installing a secondary fuel system. Install a check valve in line to prevent OBD11 system faults. Installing a secondary fuel port may affect the vehicles ability to comply with F/CMVSS 301. Final Stage Manufacturer assumes all responsibility for fuel system modifications and system compliance.

# CHASSIS CAB 4500/5500 MID-SHIP 22.5 GALLON 197.4"WB 84"CA FUEL TANK

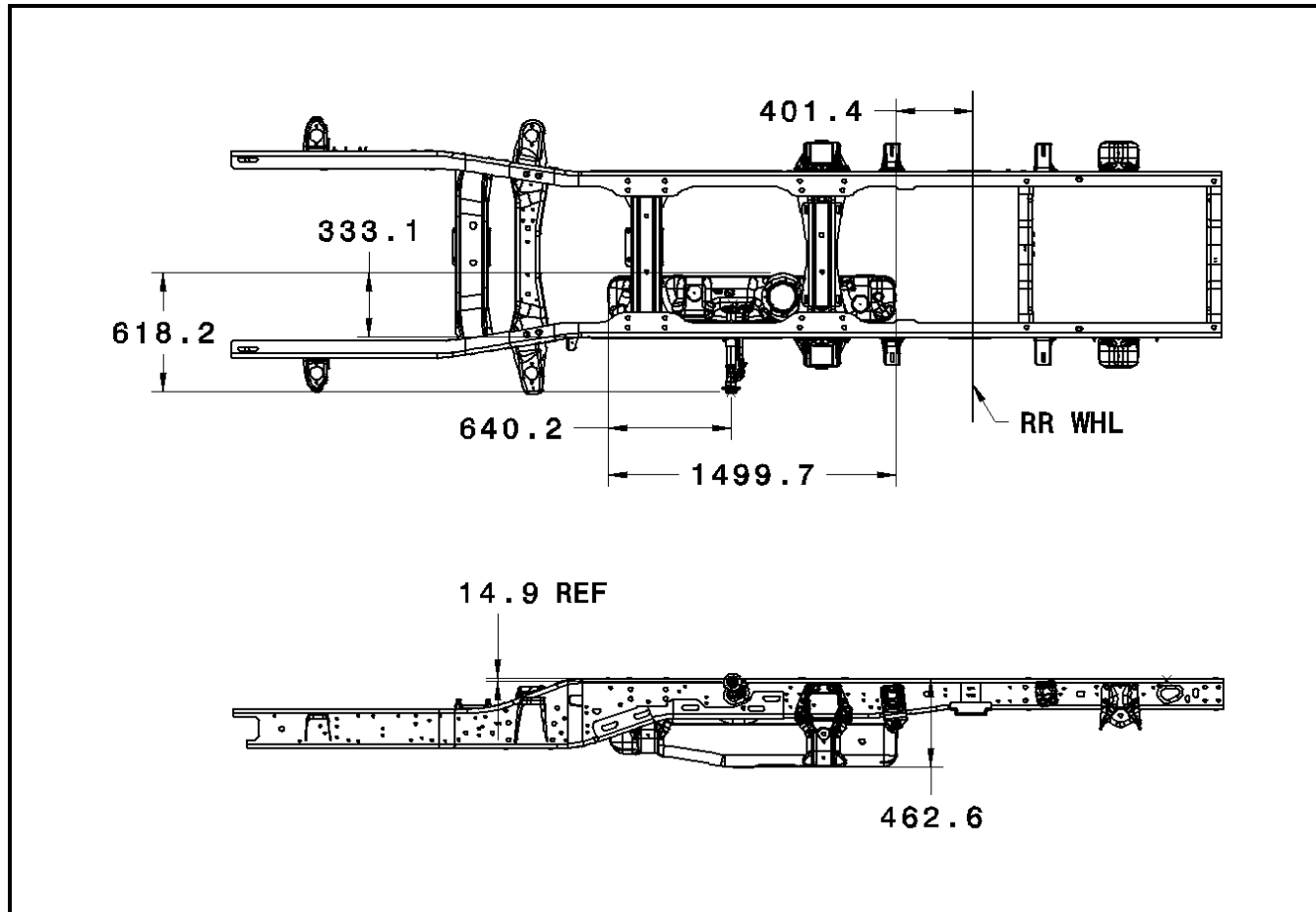

CHASSIS CAB 4500/5500  
REAR 52.2 GALLON 197.4"WB 84"CA FUEL TANK

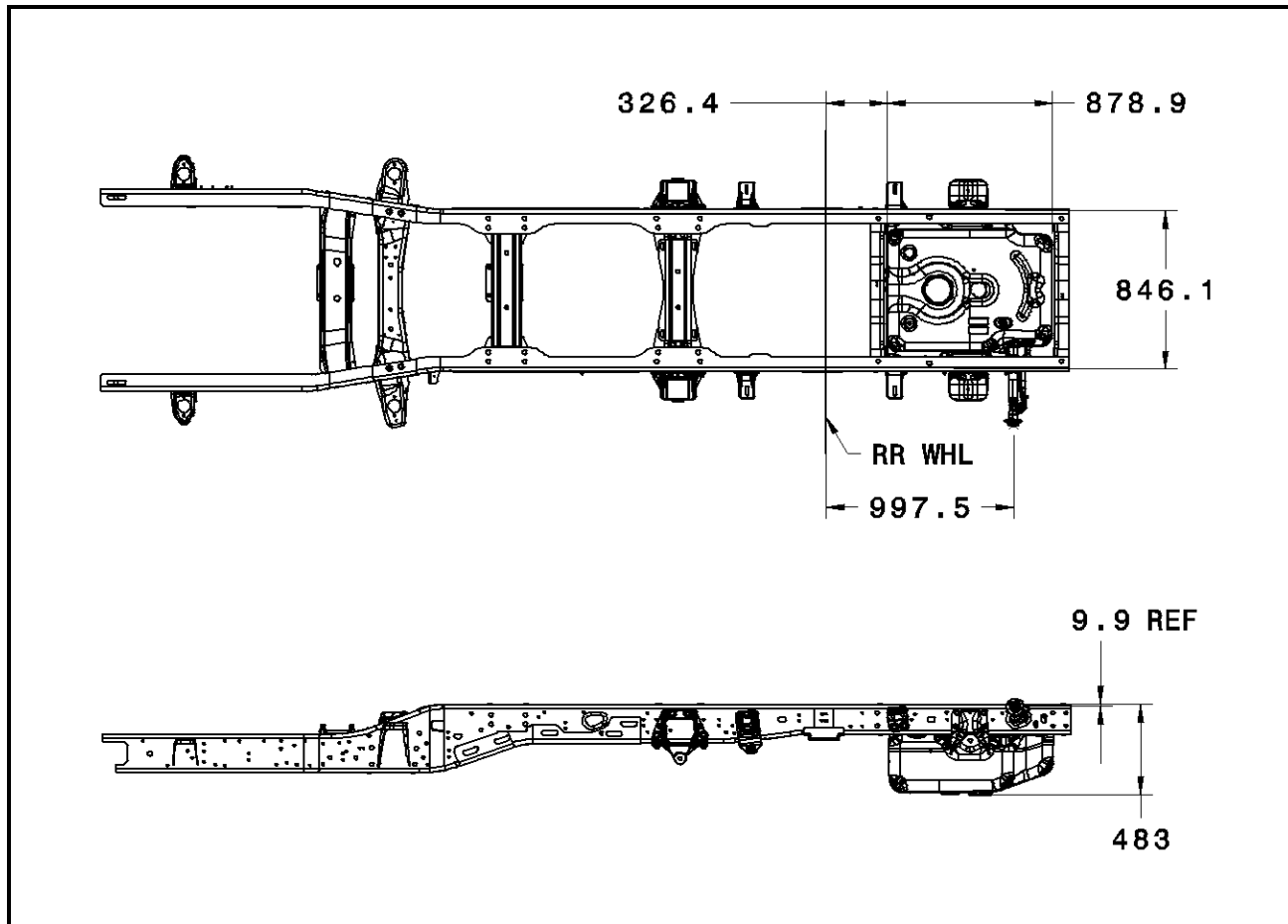

# CHASSIS CAB 4500/5500 197.4"WB 84"CA DUAL FUEL TANKS

