

2015 Occupant Restraint System Information – Ram Promaster

FRONTAL RESTRAINT SYSTEM:

ADVANCED MULTI-STAGE DRIVER AND FRONT PASSENGER AIRBAG* SYSTEM

VEHICLE MODIFICATIONS

It is imperative that all front and side restraint system components remain in their original location and orientation. This includes all seat belt components (seat belt buckle switches, retractors, adjustable turning loops and pretensioners – retractor and buckle), driver and passenger frontal airbags, left and right side SABIC's (Side Airbag Inflatable Curtain), left and right SAB's (Seat Airbag), and any occupant restraint sensing components (ORC module, pressure sensors, crush zone sensors and restraint systems wiring). Any modification, removal, or relocation of these components may be detrimental to the occupant restraint system and is prohibited.

Any vehicle modifications that may affect the deployment characteristics of the front or side airbag systems must be verified through vehicle calibration/impact testing. No modifications or equipment can obstruct the area between the steering wheel and the occupant. No modifications or equipment can obstruct the area on top of the passenger side of the instrument panel or between the passenger side of the instrument panel and the occupants.

Front Impact Restraint System: The front restraint system is comprised of the following components:

- Driver Airbag
- Front Passenger Airbag
- Driver Seat Belt Retractor with Load Limiter
- Front Passenger Seat Belt Retractor with Load Limiter
- Driver Seat Belt Buckle Pretensioner
- Front Passenger Seat Belt Buckle Pretensioner
- Driver Seat Belt Buckle Switch
- Passenger Seat Belt Buckle Switch
- Occupant Restraint Controller (ORC)
- Front and Side Airbag System Wiring

FRONT RESTRAINT SYSTEM WIRING

All front restraint system wiring must remain intact and may not be used for any other purpose. This also includes the driver and front passenger seat wiring. Any electrical connector that is yellow is part of the restraint system and should not be modified or used for other purposes.

OCCUPANT RESTRAINT SYSTEM VERIFICATION

After modification work is complete, the modifier must confirm the occupant restraint system readiness, as follows:

— Turn the ignition key on. The System Readiness lamp in the instrument cluster will illuminate for six to eight seconds, and then turn off. If the System Readiness Lamp fails to illuminate, cycles on and off, or does not turn off, the modifier must have the condition corrected by a Chrysler Group LLC dealership before shipping.

OCCUPANT RESTRAINT CONTROLLER (ORC)

The Occupant Restraint Control Module is located under the instrument panel on the floor sheet metal and is surrounded by a plastic trim cover. Care must be taken not to disturb this controller for any reason. It is also important that no modifications are made in this area, as this may affect the performance of the front airbag system.

- DO NOT modify, remove, or relocate the ORC or wiring.
- DO NOT disturb the 3 screws used to mount the ORC to the vehicle.
- DO NOT route wiring or other components in the area surrounding the ORC.
- DO NOT place anything in contact with the ORC.

SEAT BELT RETRACTORS AND PRETENSIONERS – ALL PASSENGER SEATING POSITIONS

The driver and front passenger seat belt buckle incorporate an advanced technology to limit peak force levels to an occupant torso in a severe event. Any modification, removal or relocation to the seat belt retractors is prohibited.

SEAT BELT PRETENSIONER – FRONT (DRIVER and PASSENGER) SEATING POSITIONS

The driver and front passenger seat belts buckle incorporate pretensioners that help to reduce the seat belt slack in the Seat Belt Restraint System.

SEATBELT SYSTEMS

The seatbelt system is comprised of the following components:

- Driver Seat Belt Retractor with Load Limiter
- Front Passenger Seat Belt Retractor with Load Limiter
- Driver Seat Belt Buckle Pretensioner
- Front Passenger Seat Belt Buckle Pretensioner
- Driver Seat Belt Buckle Switch
- Passenger Seat Belt Buckle Switch
- Adjustable Turning Loops
- Seat Belt Wiring

SEAT BELT WIRING

All seatbelt wiring must remain intact and may not be used for any other purpose. This also includes the driver and front passenger seat wiring. Any electrical connector that is yellow is part of the restraint system and should not be modified or used for other purposes.

2015 Occupant Restraint System Information – Ram Promaster

KNEE BLOCKER/LOWER STEERING COLUMN COVER AND PASSENGER SIDE OF LOWER INSTRUMENT PANEL

The lower steering column cover area and glove box, also known as “Knee Blockers,” are integral parts of the airbag restraint system. These areas include energy-absorbing features and must not be removed or modified in any manner, including the attachment of any auxiliary switches or parts.

*Certified to the Federal Regulations that allow less forceful front airbags. Always use seat belts. Children 12 and under should always be in a back seat correctly using an infant or child restraint system, or a seatbelt that is right for their age and size.

STEERING COLUMN

In order for the steering column to perform properly, it must not be modified in any manner. This includes all components that are adjacent to or attached to the steering column, such as the steering wheel, the shrouds, and the upper and lower support brackets. Caution must also be exercised to ensure that nothing is placed in the axial path of the steering column, nor that any of the designed clearance gaps are disturbed.

FRONT BUMPER SYSTEM

If the front bumper and bumper mounting system are removed temporarily, the front bumper and bumper mounting system must be reinstalled in accordance with the instructions provided in the current minivan service manual. The front bumper and bumper mounting system cannot be replaced with parts other than OEM. The crash sensing of the front airbag systems is tuned, in part, to the front bumper. The original front bumper system (beam, brackets and fascia) must be retained. No modifications, deletions or additions to the bumper (i.e. bumper-mounted bicycle racks, etc) are permitted.

SIDE RESTRAINT SYSTEM:

VEHICLE MODIFICATIONS

It is imperative that all front and side restraint system components remain in their original location and orientation. This includes all seat belt components (seat belt buckle switches, retractors, adjustable turning loops and pretensioners), driver and passenger frontal airbags, left and right side SABIC's, left and right SAB's and any occupant restraint sensing components (ORC module, pressure sensors, crush zone sensors and restraint systems wiring). Any modification, removal, or relocation of these components may be detrimental to the occupant restraint system and is prohibited.

Any vehicle modifications that may affect the deployment kinematics of the side airbag restraint systems, SABIC (Side Airbag Inflatable Curtain) or SAB (Seat Airbag) airbag systems must be verified through vehicle calibration/impact testing. No modifications or equipment can obstruct the area between the Driver and Passenger Door Trim and the occupants. Obstructing these zones is prohibited.

Any modifications on vehicles with SABIC's must not allow for dividers, cages, boxes or any rigid structure within a zone of: 10 inches of the headliner to the top of door, front to rear down to the beltline (bottom of door glass) Any objects permanently placed within this zone will compromise the SABIC during deployment.

Any modifications or coverings on the seats will affect the deployment characteristics of the SAB's. Any object placed in the deployment zone will compromise the SAB during deployment.

Side Impact Restraint System

The side impact restraint system is comprised of the following components:

- SABIC – Side Airbag Inflatable Curtain
- SAB – Seat Airbag
- Driver Seat Belt Retractor with Load Limiter
- Front Passenger Seat Belt Retractor with Load Limiter
- Driver Seat Belt Buckle Pretensioner
- Front Passenger Seat Belt Buckle Pretensioner
- Driver Seat Belt Buckle Switch
- Passenger Seat Belt Buckle Switch
- Occupant Restraint Controller (ORC)
- Side Crush Zone Sensors – Lower B-Pillars
- Side Airbag System Wiring

SIDE RESTRAINT SYSTEM WIRING

All side restraint system wiring must remain intact and may not be used for any other purpose. This also includes the driver and front passenger seat wiring. Any electrical connector that is yellow is part of the restraint system and should not be modified or used for other purposes.

SIDE AIRBAG INFLATABLE CURTAIN (SABIC)

The supplemental side airbag inflatable curtains (SABIC) are located behind the headliner above the doors following the full length of the roof side rail, including a SABIC tethers behind the A-pillars and D-pillars.

Zone of Operation: The full length of the headliner, from A-pillar to D-pillar, on each side of the vehicle. The SABIC covers from the Headliner/Garnish trim interface, down to the beltline. Obstructing the deployment zone of the SABIC is prohibited.

SEAT AIRBAG (SAB)

The supplemental seat-mounted side airbags (SAB) are located in the outboard bolsters of the driver and passenger seatbacks. The sew seam of these bolsters are utilized as the tearseams for the SAB deployment.

2015 Occupant Restraint System Information – Ram Promaster

Zone of Operation: The SAB deploys out of the sew seam of the outboard seatback bolster. It deploys from the bolster forward in vehicle, between the front door trim and the occupant, covering the occupant's torso and pelvis.

Obstructing the deployment zone of the SAB is prohibited.

SEAT COVERS MUST NOT BE USED TO COVER THE ORIGINAL EQUIPMENT.

Vehicles equipped with the supplemental side airbag system can be identified by **ANY** of the following:

- "SRS AIRBAG" (Supplemental Restraint System) embossed on the face of the "B" & "C" pillar attachment plugs.
- Tags sewn in the sew seam (tearseam) of the front seat's outboard seat bolsters
- Warning label on the rear face of the front doors above the latch
- The third character in the VIN is "8"
- Monroney label

OCCUPANT RESTRAINT SYSTEM VERIFICATION

After modification work is complete, the modifier must confirm the occupant restraint system readiness, as follows:

— Turn the ignition key on. The System Readiness lamp in the instrument cluster will illuminate for six to eight seconds, and then turn off. If the System Readiness Lamp fails to illuminate, cycles on and off, or does not turn off, the modifier must have the condition corrected by a Chrysler Group LLC dealership before shipping.

OCCUPANT RESTRAINT CONTROLLER (ORC)

The Occupant Restraint Control Module is located under the instrument panel on the floor sheet metal and is surrounded by a plastic trim cover. Care must be taken not to disturb this controller for any reason. It is also important that no modifications are made in this area, as this may affect the performance of the side airbag system.

- DO NOT modify, remove, or relocate the ORC or wiring.
- DO NOT disturb the 3 screws used to mount the ORC to the vehicle.
- DO NOT route wiring or other components in the area surrounding the ORC.
- DO NOT place anything in contact with the ORC

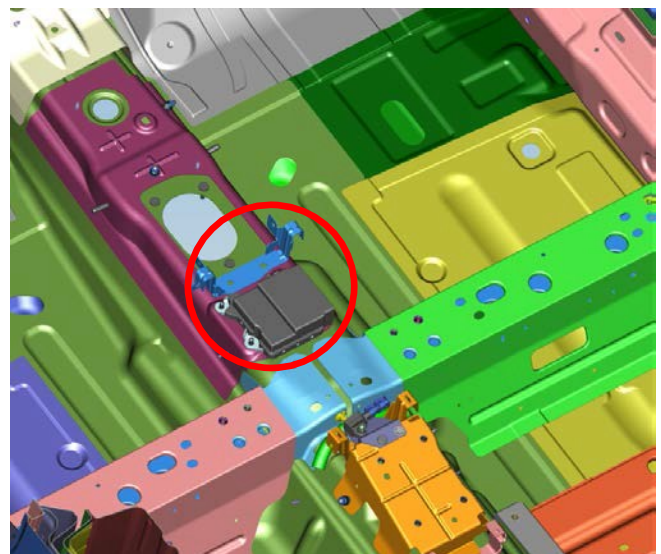
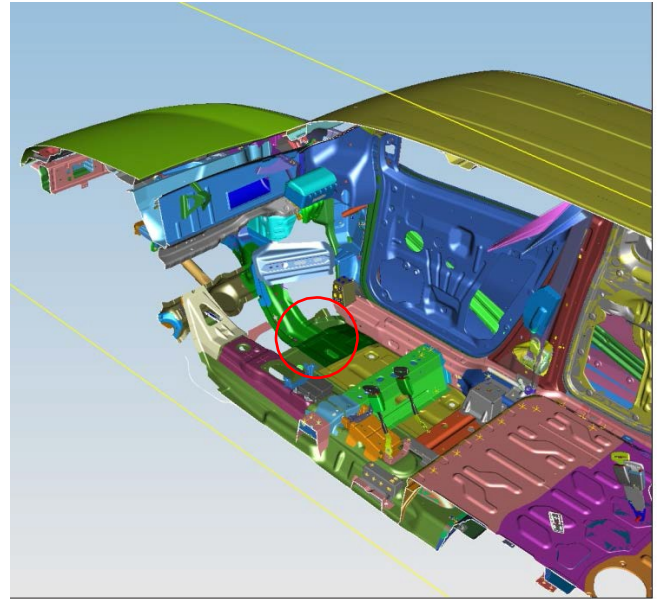

ACTIVE HEAD RESTRAINT HEADRESTS (If equipped)

- DO NOT modify or remove Active Head Restraint headrests or wiring.

SABIC Packaging in BIW

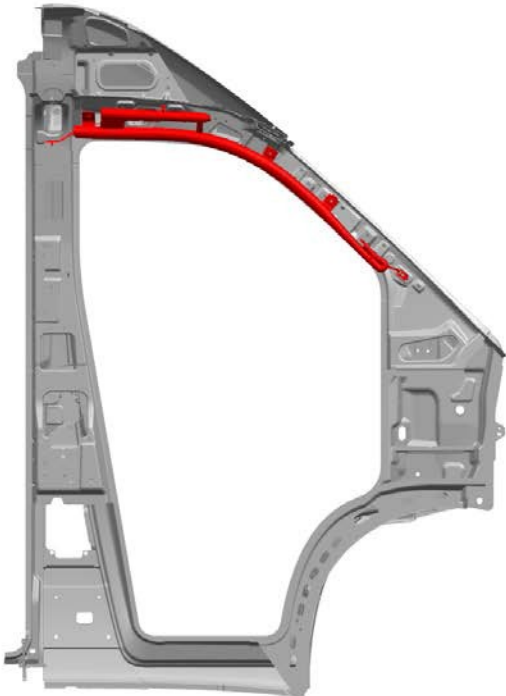

VM SABIC Packaging in BIW



2015 Occupant Restraint System Information – Ram Promaster

Side Curtain Airbag Deployment Zone

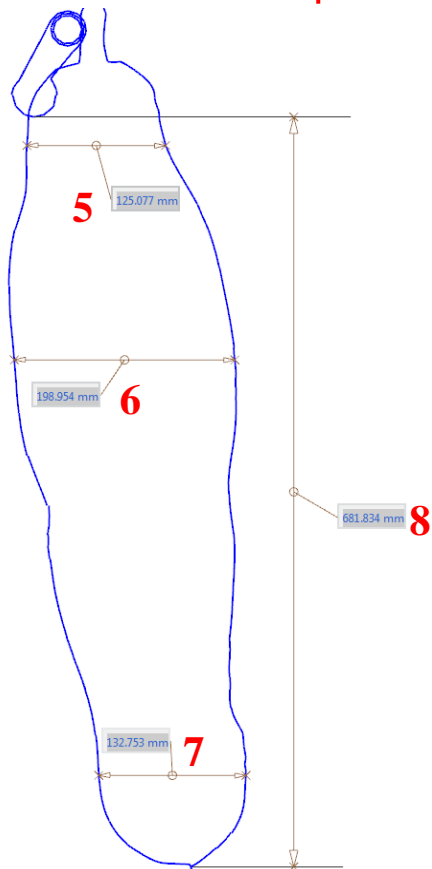
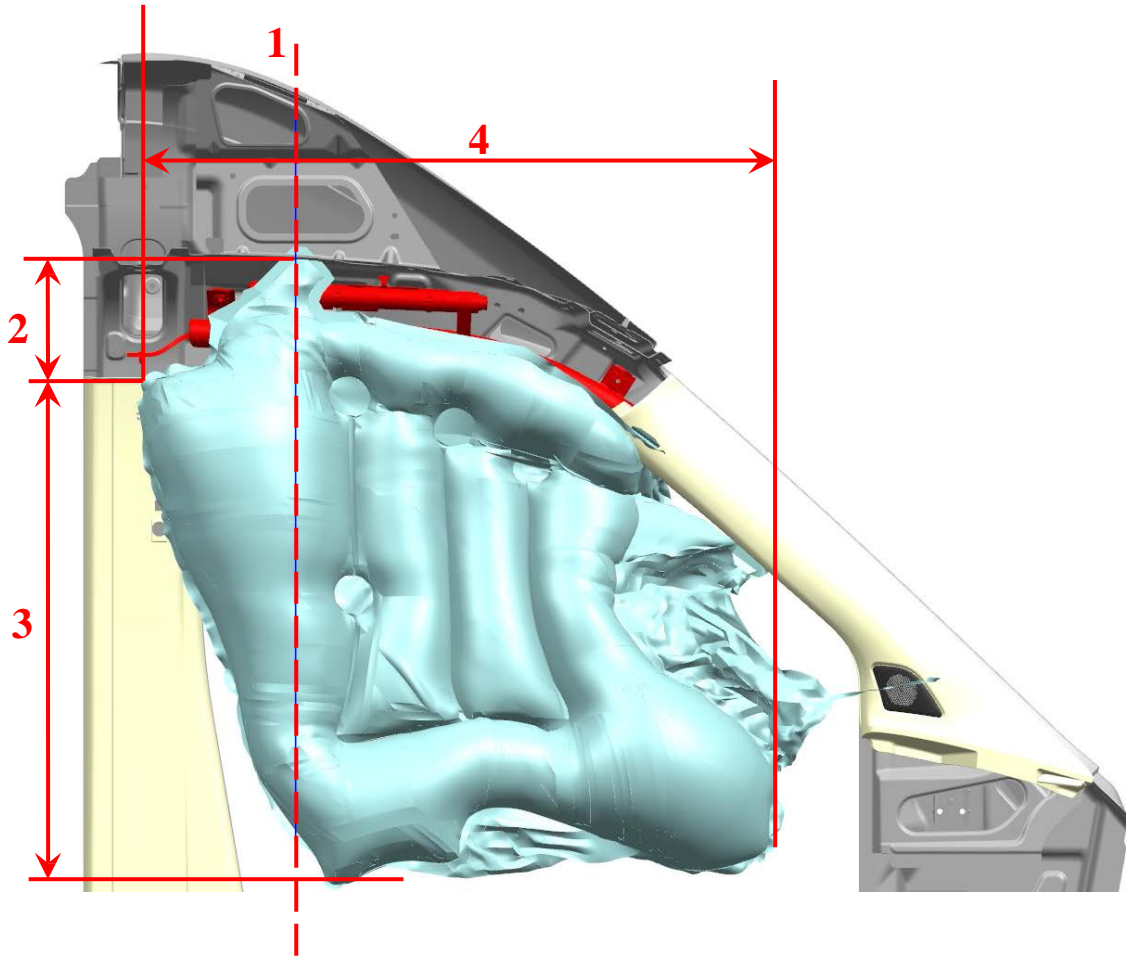

1	Cross Section	5	125
2	186.5	6	199
3	720	7	133
4	893	8	682

All dimensions are in millimeters.

2015 Occupant Restraint System Information – Ram Promaster

Side Curtain Airbag Deployment Zone

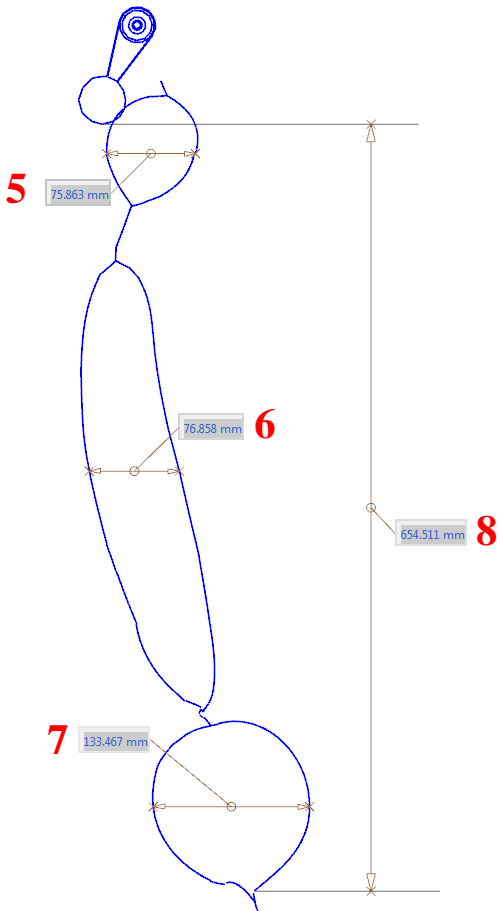
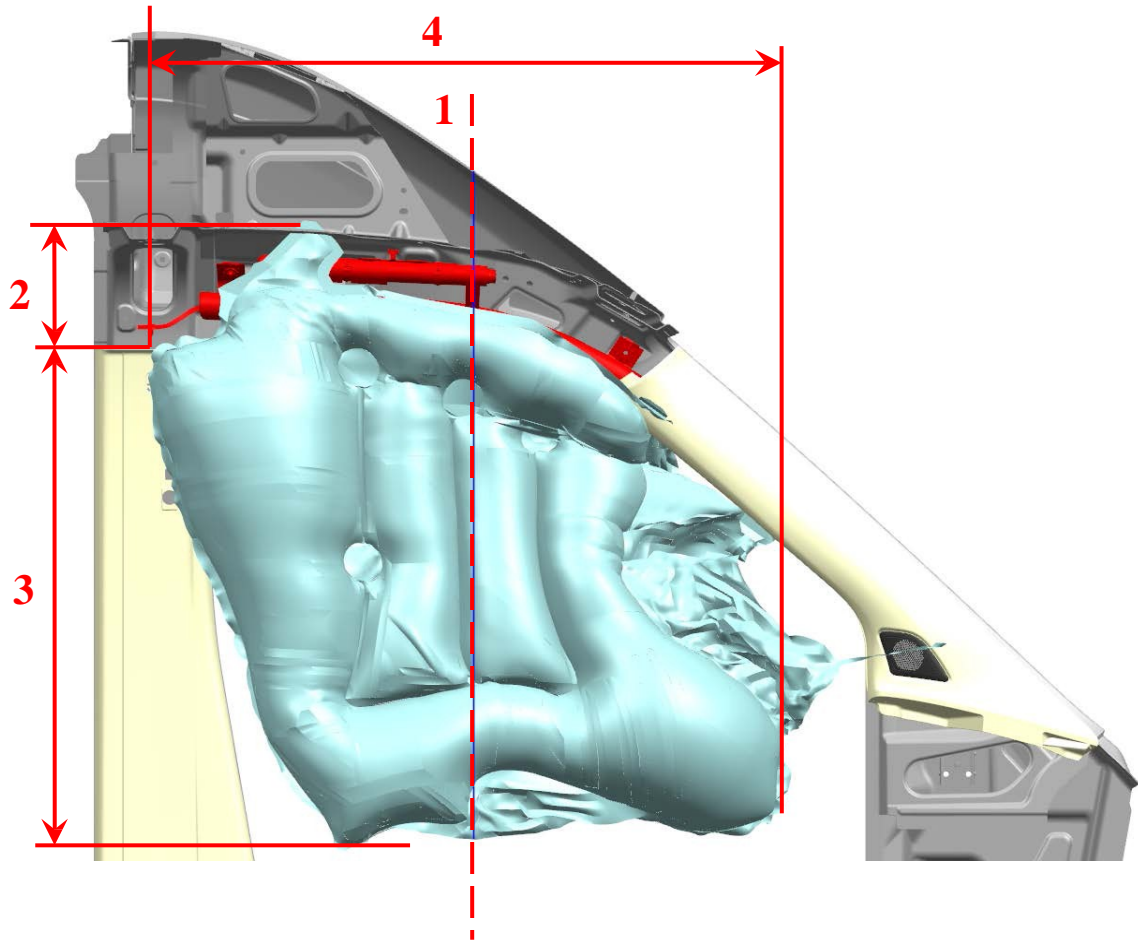

1	Cross Section	5	76
2	186.5	6	77
3	720	7	133.5
4	893	8	654.5

All dimensions are in millimeters.

Side Airbag Deployment Zone

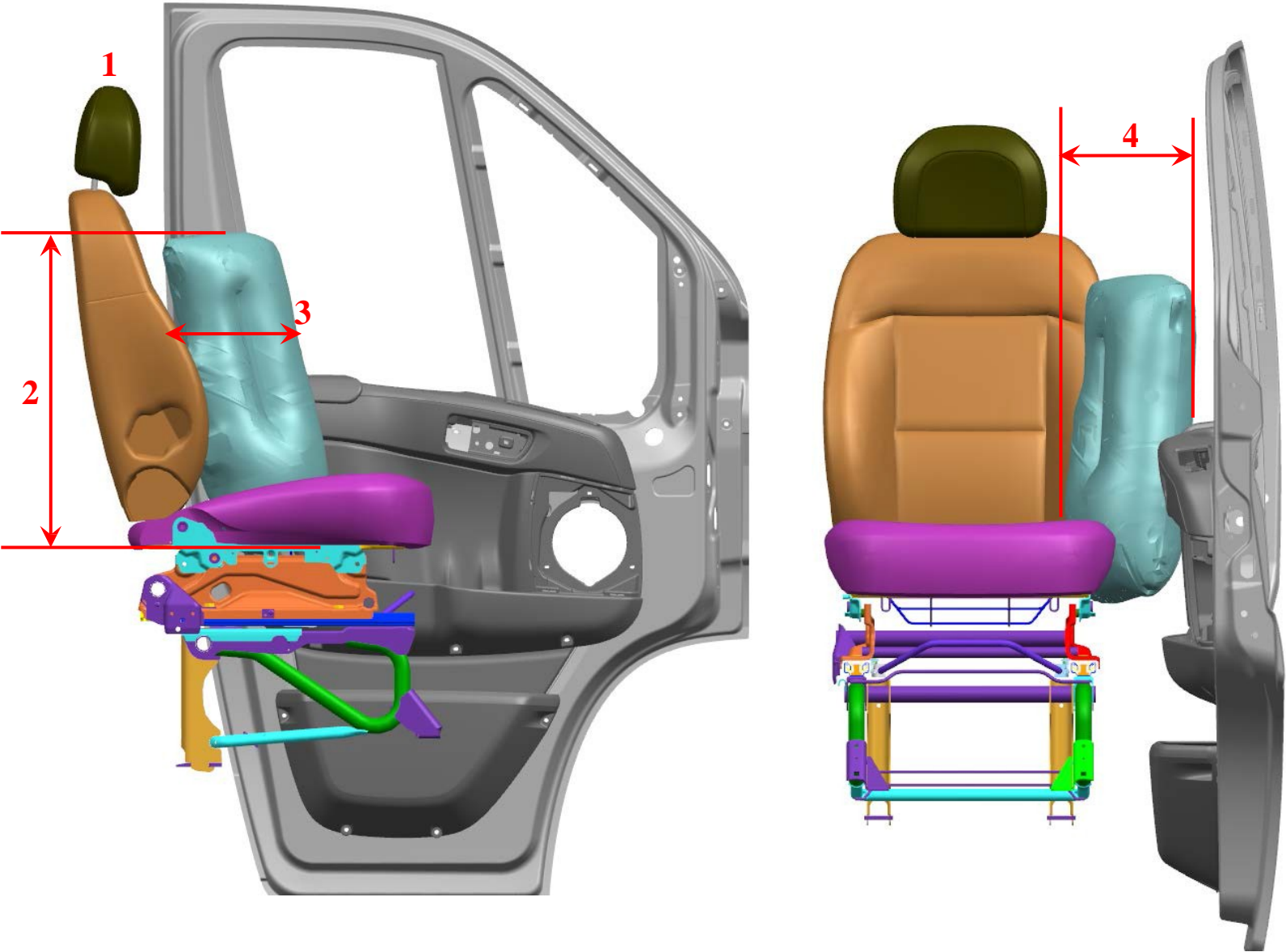

1	Front driver seat	3	250
2	594	4	203

All dimensions are in millimeters.

Driver Airbag Deployment Zone

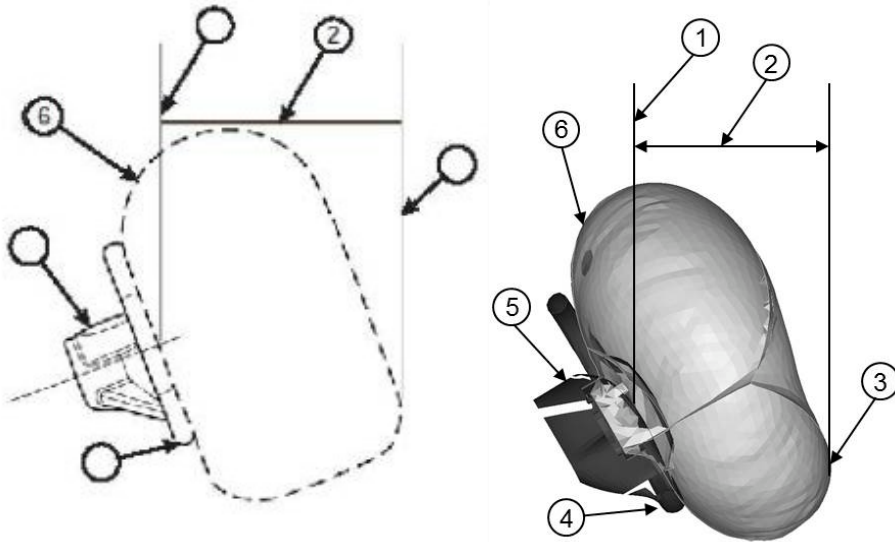

1	Vertical Plane Passing Through the Center of the Steering Wheel	4	Steering Wheel
2	285mm	5	Driver Airbag Retainer/Housing
3	Vertical Plane Passing Through the Maximum Rearward Point That the Driver Airbag Cushion Reaches	6	Driver Airbag Cushion

Driver Airbag Deployment Zone

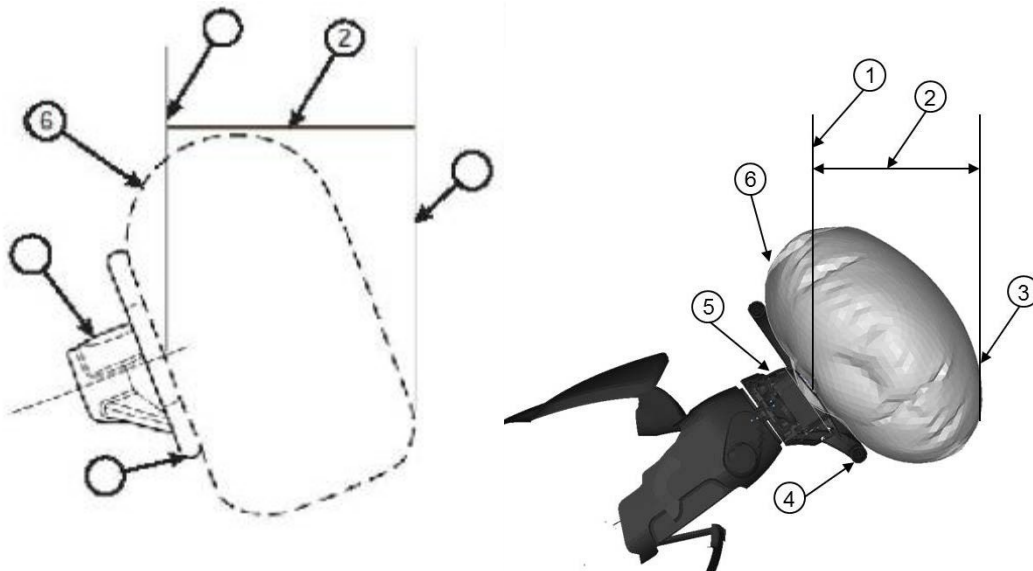

1	Vertical Plane Passing Through the Center of the Steering Wheel	4	Steering Wheel
2	350mm	5	Driver Airbag Retainer/Housing
3	Vertical Plane Passing Through the Maximum Rearward Point That the Driver Airbag Cushion Reaches	6	Driver Airbag Cushion

2015 Occupant Restraint System Information – Ram Promaster

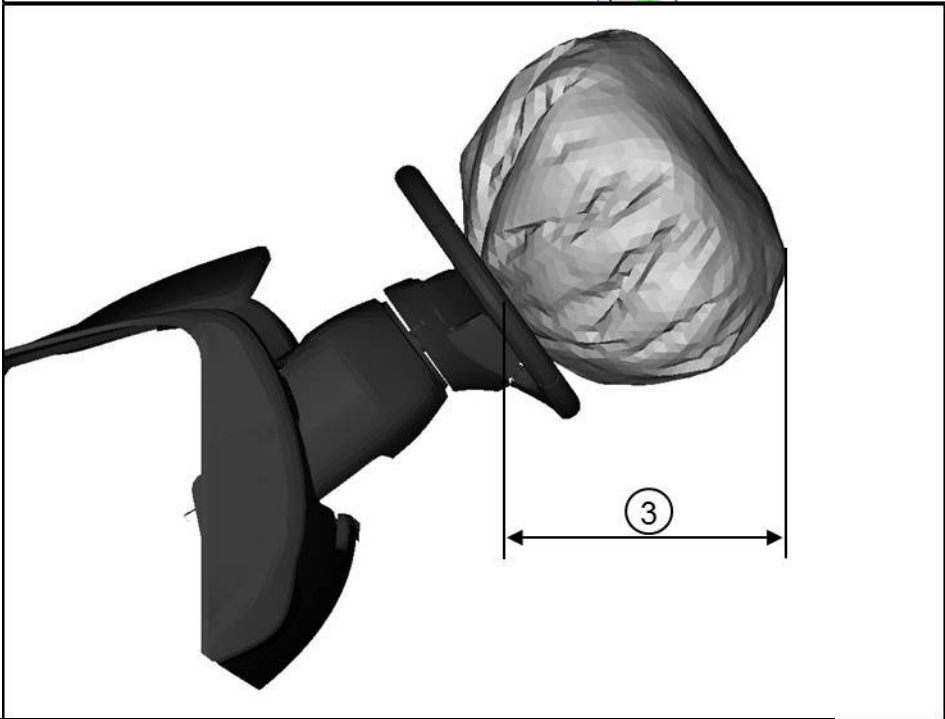
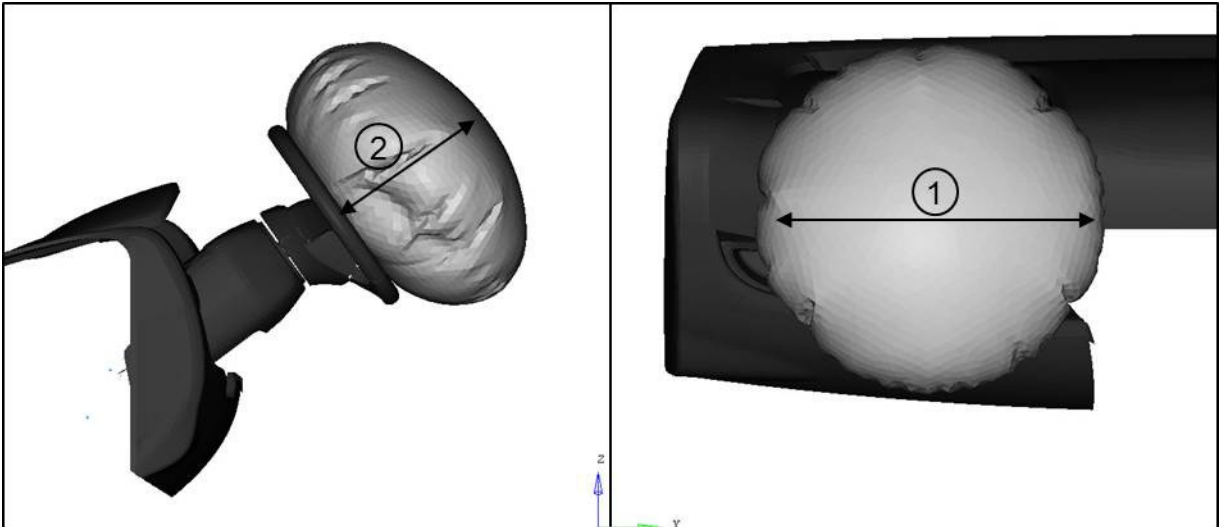

1. DAB diameter when full	530
2. DAB depth when full	330
3. Maximum rearward displacement during fill	385

Passenger Airbag Deployment Zone

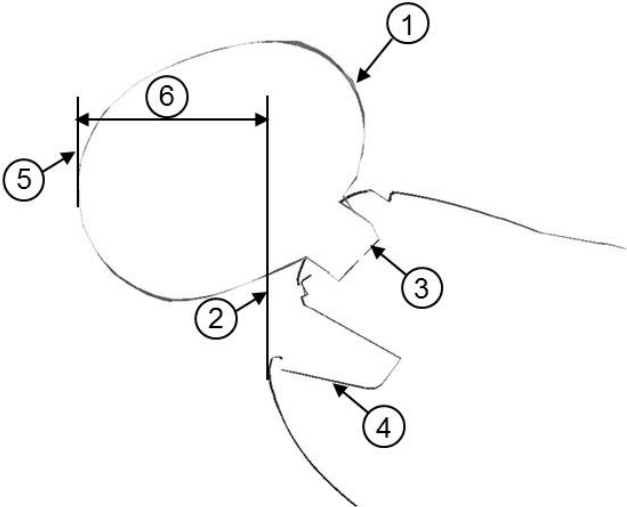
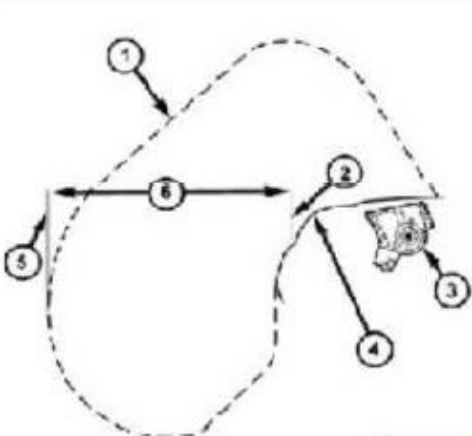

1	Passenger Airbag Cushion	4	Instrument Panel
2	Vertical Plane From Point of Instrument Panel	5	Vertical Plane Passing Through The Maximum Rearward Point That The Passenger Airbag Cushion Reaches
3	Passenger Airbag Module	6	300mm