

2015 PROMASTER TRAILER BRAKE CONTROLLER INSTALLATION

ProMaster Trailer Brake Controller Installation

The ProMaster does not have a factory equipped connector for trailer brake controller installation. Aftermarket trailer brake controllers may be installed by splicing the brake controller circuits into the existing vehicle circuitry.

Please review and become familiar with the installation instructions supplied with the trailer brake controller. These instructions will provide detailed information about the trailer brake controller.

The trailer brake controller typically requires an active high brake switch input. In other words, the wire from the brake switch that goes from zero volts with the service brake released to battery voltage when the service brake is pressed. For the ProMaster, the active high circuit is in Pin 4 of the brake switch connector. The brake switch is located on the bracket above the brake pedal.

Located above brake pedal behind IP



Battery Feed

2015 PROMASTER TRAILER BRAKE CONTROLLER INSTALLATION

Below is a drawing of the brake switch connector. This is a view of the wire entry side of the harness connector. The brake switch wire coming from the brake controller can have different names and wire colors depending on the manufacturer of the controller. Typically, this is a smaller gage red wire called something like "stop lamp switch" or "brake switch." Splice the wire from the trailer brake controller into the wire coming out of pin 4. It is a green wire with a white tracer.

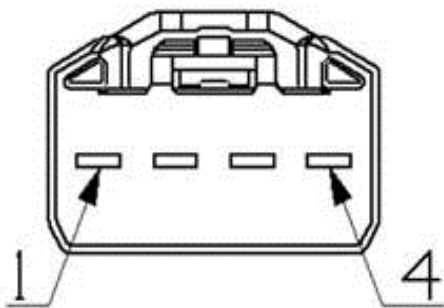

1	L53	LB	Stop Lamp Feed 1
2	K51	LB	Stop Lamp Signal / CHMSL Feed
3	B15	WT/LB	Brake Active Sense
4	B135	GR/WT	Pedal Force Switch - NO



Battery feed for the brake controller is most easily found on one of the terminals on the battery. However, power from any other convenient location can be used providing it is capable of delivering the amount of current required by the brake controller. Once again, wire names and colors may vary depending on manufacturer. Typically, the battery feed is a larger gage black wire. It is recommended that an auto resetting circuit breaker be used in the battery input circuit. Please see brake controller guidelines for circuit breaker rating, wire size and current requirements. Typically this should be in the area of 25 amps and 12 AWG.

A ground point for the brake controller can be any well suited chassis ground or the negative terminal of the battery. For the brake controller, this is typically a white larger gage wire. Should additional wire length be needed, use the wire size recommendations of the brake controller. This should be around 12 AWG wire.

The brake output wire going from the brake controller to the trailer brakes is typically a larger gage blue wire. This circuit should be routed to the trailer connector at the rear of the vehicle. If an aftermarket trailer connector is being used, connect the brake output wire to the pin on the trailer connector that is being used for the trailer brake circuit. See brake controller guidelines for wire size. Typically this should be around 12 AWG.

2015 PROMASTER TRAILER BRAKE CONTROLLER INSTALLATION

There is a MOPAR kit available for trailer lighting. There are a couple of different revision levels of this kit. If you have part number is 82213930AA or 82213930AB, the kit will supply everything needed for trailer lighting including the circular 7 pin "POLLAK" trailer connector that snaps into the mounting bracket that is on the MOPAR hitch.

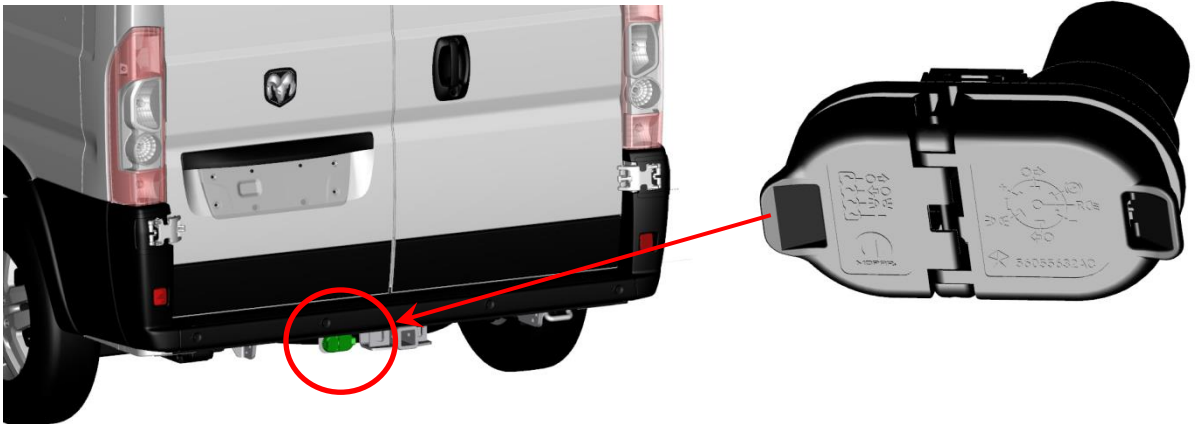

The AA and AB versions do not have provisions for the trailer brake circuit. MOPAR is releasing an "AC" version that will have the brake control wire in the harness. That kit should be available early in the third quarter of 2014.

If you are using an AC level kit or greater, you do not have to route the extra brake wire to the rear of the vehicle. Simply connect the brake output wire of the controller to the blue wire in the MOPAR trailer harness.

If you are using an AA or AB level kit, you will need to connect a circuit to the brake output wire of the trailer brake controller and route it to the circular vehicle harness connector that plugs into the trailer connector. Crimp a terminal and seal (see note below) on to the end of the wire.

NOTE: If you do not have access to the terminal, seal or crimp tool, please contact Ram BBG by email at rambbg@chrysler.com or by phone at 866-205-4102 for more information.

Remove the circular harness connector from the trailer connector

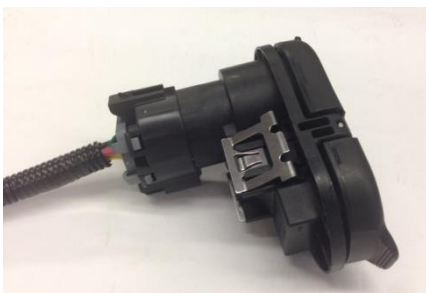

2015 PROMASTER TRAILER BRAKE CONTROLLER INSTALLATION

Remove the grey lock on the back of the harness connector

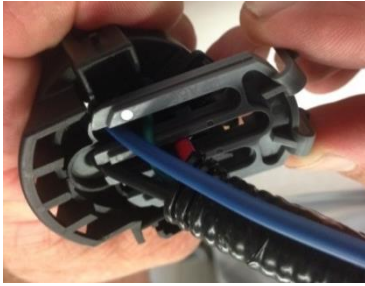

Remove the green rubber plug from the back of the connector



Insert the wire with terminal into the back of the connector, when fully seated, you should not be able to pull the terminal back out



Re-install the lock and re-attach the harness connector to the trailer connector



Mount the trailer brake controller in a convenient location somewhere near the driver. Some systems require that the brake controller be level others do not. You will want the controller be in a location where the driver can easily access the manual brake control. Mount the controller per the guidelines for the trailer brake controller.