

Satellite Radio & Cellular Antenna Relocation Guidelines

If an upfitter package's proximity to the satellite/cellular mobile media antenna causes interference with satellite and/or onboard cellular reception, the antenna may be able to be relocated to allow for better reception. There is a wide variation of up fitter packages and customer usages making specific relocation instructions difficult. The following is a set of guidelines and information that should allow the up fitter to acquire the needed parts and relocate the antenna to a more suitable location.

There are two types of antennas that may be factory installed on the truck, the "Shark Fin" and the "Puck." The shark fin is used for vehicles equipped with satellite radio/navigation (SDARS) AND Cellular Mobile Media. (U Connect Access Advantage) The puck is installed on vehicles with SDARS only.

If there is a shark fin, there will be two antenna wires. One is for SDARS and the other is for cellular. The sat radio wire is different from the cellular wire. The connectors on the two sets of wire are different. The two cannot be interchanged. The puck will only have one antenna wire used for SDARS radio.

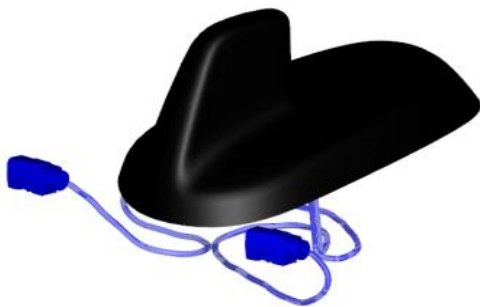

Shark Fin – 2 wires



Puck – 1 wire

2013 SATELLITE RADIO & CELLULAR ANTENNA RELOCATION GUIDELINES

There are connections for both the SDARS and cellular antennas on the back of the radio depending upon which radio option the truck is equipped with.

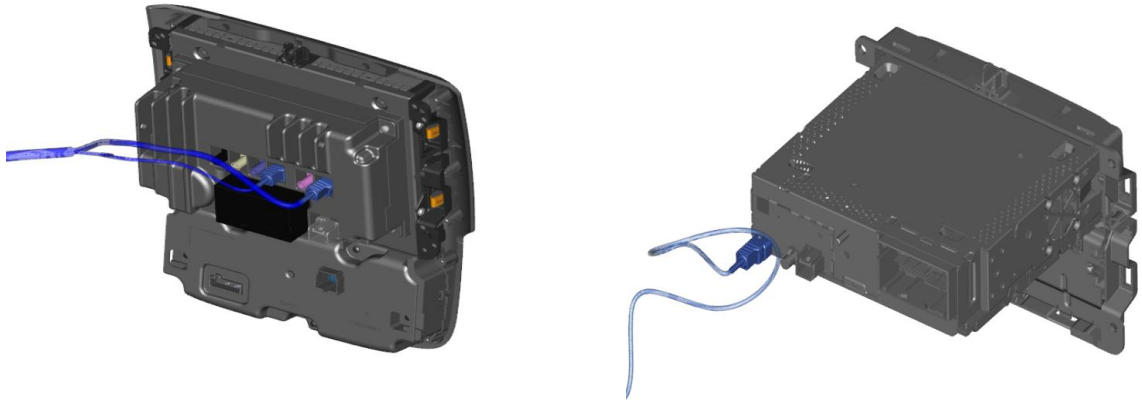

There will be a relatively short length of antenna wire (jumper) running from the radio to a location near the base of the passenger side A pillar. This connection can be accessed by removing the A pillar trim panel. There is another length of antenna wire running from there, up the A pillar, under the head liner to the antenna.

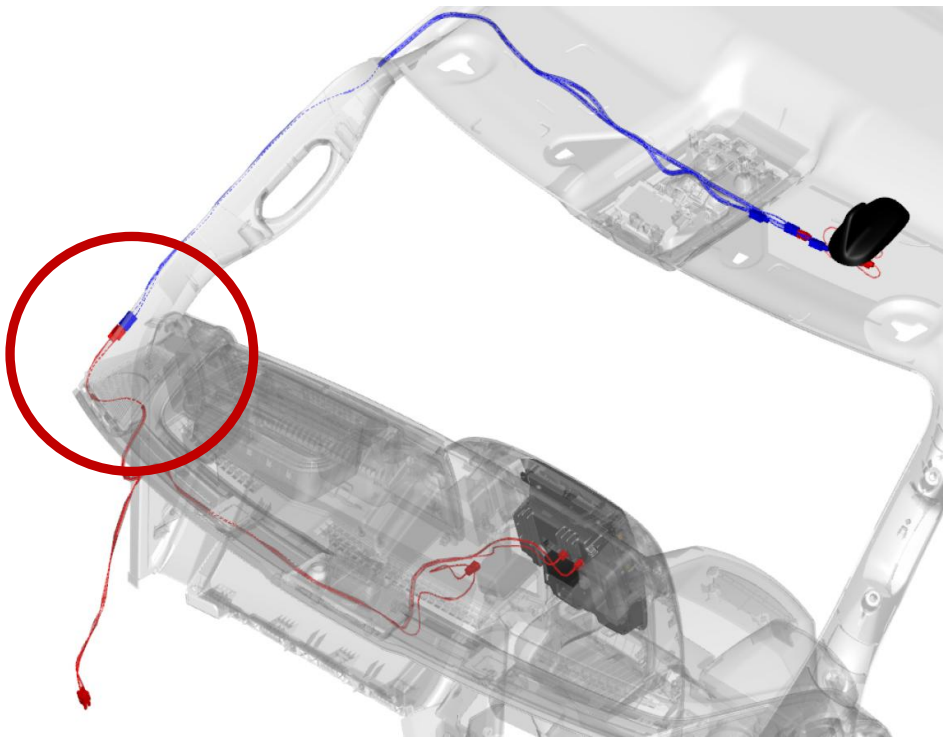

2013 SATELLITE RADIO & CELLULAR ANTENNA RELOCATION GUIDELINES

The antennas, cables and radios all have common connections for the SDARS and common connections for the cellular. You will not be able to use a cellular cable for SDARS or the SDARS cable for cellular.

CELL / SDARS – 2 Wires

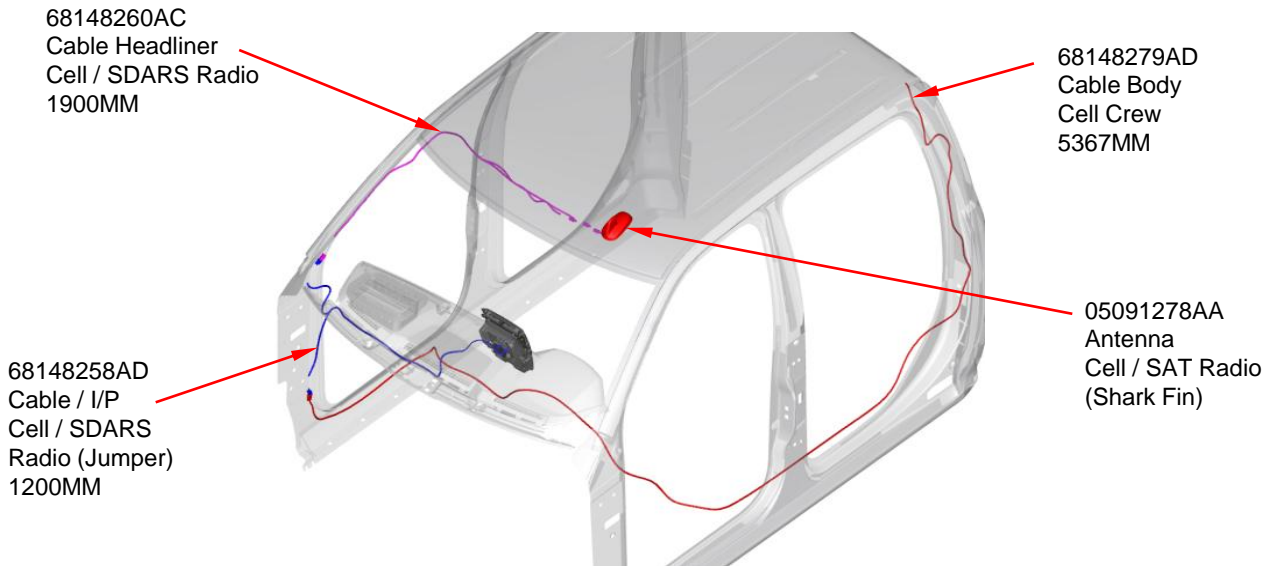

SDARS – 1 Wire

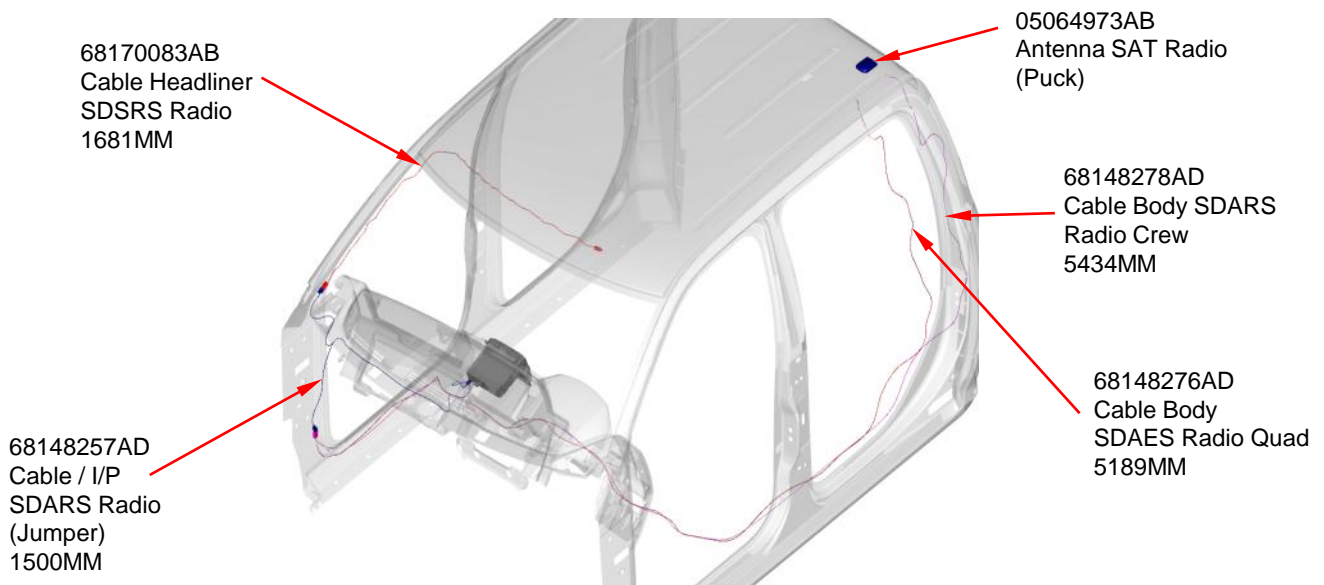

2013 SATELLITE RADIO & CELLULAR ANTENNA RELOCATION GUIDELINES

The cables can be used like extension cords and be plugged together to create whatever cable length is needed. However, antenna cable length and connections will cause signal degradation. In order to maintain the manufacturer's specified system performance, the total cable length from antenna connection to the radio connection **should not exceed 7300 mm** with three antenna connections. The factory installed system has three connections. One at the radio, one at the antenna and one in-line at the passenger side A pillar. **For every additional in-line connection, 1100 mm of cable length should be subtracted from the 7300 mm max.**

The hardware on the base of the antenna and the antenna connections anywhere in the cable are not weather proof. Some sort of enclosure will need to be fabricated at the remote antenna location replicating the antenna mounting and sealing found in the factory antenna location on the roof of the cab. The antenna base hardware and antenna connection should be completely sealed in the enclosure from the outside environment. The antenna cable pass through into the enclosure should be through some sort of grommet arrangement protecting the cable from chafing and should be sealed. The antenna cable pass through in the vehicle's body should also be some sort of grommet arrangement and be sealed. Any in line connections in the antenna cable must also be sealed from the outside environment.

It is highly recommended that an additional antenna be used in the remote location and that the antenna not be removed from the vehicle. There is no good way to seal the mounting and pass through holes that will be left in the roof of the cab once the antenna is removed. This could cause leaks and may result in the manufacturer's warranty being voided. Antennas can be purchased from the dealer and used in the remote location leaving the factory antenna in place to keep the roof sealed.

2013 SATELLITE RADIO & CELLULAR ANTENNA RELOCATION GUIDELINES

There are two recommended locations for plugging the remote antenna cable into the vehicle system.

1. The back of the radio.

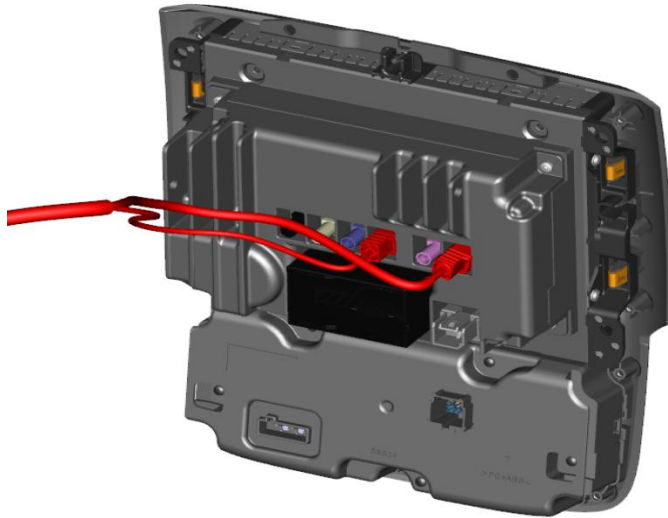

2. The Jumper near the A pillar

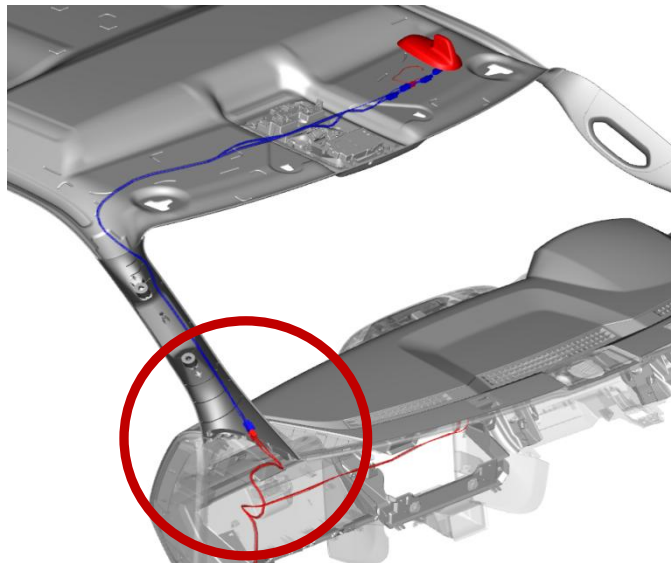

Choose the one that works best with your individual mounting location and antenna cable length/interconnect budget requirements.

2013 SATELLITE RADIO & CELLULAR ANTENNA RELOCATION GUIDELINES

This section of antenna wire is available in variety of different lengths depending upon the type of cab and antennal location on the roof. If the vehicle is equipped with SDARS only, there will be only one antenna wire. If it has SDARS and cellular, there will be two antenna wires.

All of the antennas and wires are available through the dealer. It is recommended that you choose the shortest cable possible to get from the vehicle interconnect point to the remote antenna. The following is a list of P/N's:

Part Number	Physical Description	Length (mm)
68148257AD	CABLE I/P SDARS RADIO (Jumper)	1500
68148258AD	CABLE I/P CELL/SDARS RADIO (Jumper)	1200
68148260AC	CABLE HEADLINER CELL/SDARS RADIO	1900
68170083AB	CABLE HEADLINER SDSRS RADIO	1681
68148276AD	CABLE BODY SDAES RADIO QUAD	5189
68148277AD	CABLE BODY CELL QUAD	5196
68148278AD	CABLE BODY SDARS RADIO CREW	5434
68148279AD	CABLE BODY CELL CREW	5367
05091278AA	ANTENNA CELL/SAT RADIO (SHARK FIN)	NA
05064973AB	ANTENNA SAT RADIO (PUCK)	NA